

AGENDA ITEM FOR ADMINISTRATIVE MEETING

( ) Discussion only  
( X ) Action

FROM (DEPT/ DIVISION): County Counsel

SUBJECT: Construction Contract – Ordnance Pipeline

<p>Background: The County issued a Request for Proposals for the general contractor for the Ordnance Pipeline project. Two proposals were received - from Rotschy Inc. and Tapani Inc. After a technical review of the proposals by the consultants and staff, the recommendation is to award the contract to Tapani.</p>	<p>Requested Action: Approve notice of intent to award contract for general contractor for Ordnance Pipeline project to Tapani Inc. in the amount of \$6,718,202</p>
---	--

ATTACHMENTS: Proposals

Checkoffs:

- ( ) Dept. Head (copy)
- ( ) Budget (copy)
- ( ) Legal (copy)

To be notified of Meeting:

\*\*\*\*\*

Scheduled for meeting on: April 26, 2023

Action taken:

**GENERAL CONTRATOR RFP  
ORDNANCE MULTI-USE WATER PROJECT**



**ROTSCHY INC.  
7408 NE 113<sup>TH</sup> CIRCLE  
VANCOUVER, WA**



## TRANSMITTAL LETTER

April 19<sup>th</sup>, 2023

Umatilla County Board of Commissioners  
216 S. E. 4<sup>th</sup> Street, Umatilla, Oregon 97801

Re: RFP - Ordnance Multi-Use Water Project

To whom it may concern:

Rotschy, Inc. is pleased to submit this proposal for the Ordnance Multi-Use Water Project. We are proposing a uniquely qualified team able to complete the project within the Umatilla County and IRZ Consulting's expectations.

- **Experience** – We have a proven portfolio of successfully constructed large complex water pump stations, and water pipeline projects in the Pacific Northwest.
- **Resourceful** - We employ more than 450 people and own over 350 heavy equipment machines. Our labor force includes over 170 laborers, 95 equipment operators, 53 supervisors and foremen.

Our primary point of contact for this project will be:

Darin Kysar, PM | 360.334.3100 | [darink@rotschyinc.com](mailto:darink@rotschyinc.com)

Rotschy, LLC. dba Rotschy, Inc. 7408 NE 113<sup>th</sup> Circle, Vancouver, WA. 98662

Any contract documents executed with the County will be signed by one of Rotschy's four owners: brothers, Brent Rotschy, Page Rotschy, Drew Rotschy, and Cornell Rotschy. Rotschy Inc. acknowledges receipt of Addendum No. 1 dated April 12, 2023. If selected as the Contractor for this project, Rotschy will be committed to the obligations in our proposal. Please do not hesitate to contact us should you have further questions or concerns.

Sincerely,

A handwritten signature in blue ink, appearing to be "D. Rotschy", written over a light blue horizontal line.

Drew Rotschy, Vice President

**Umatilla County  
Ordinance Multi-Use Water Project  
General Contractor ITB-009  
Addendum #1 Acknowledgment Form**

**Prepared by IRZ Consulting, LLC  
4/12/2023**

Instructions: Please acknowledge receipt of Addendum #1 issued with this bid package by completing this addendum acknowledgment form. Failure to acknowledge addenda may result in bid disqualification.

I understand that any verbal representation made or assumed to be made during any oral discussion held between Contractor and Owner or Owner's representatives is not binding. Only the information issued in writing and added to the bid package by an official addendum is binding.

Company: Rotschy, LLC. dba Rotschy, Inc.

Authorized Signature: \_\_\_\_\_



Date: 4/19/2023

**NOTE:** This addendum acknowledgement shall be submitted with the bid.



April 10, 2023

I hereby certify that I am secretary of Rotschy, LLC dba Rotschy Inc., a Washington Limited Liability Company organized and established July 31, 1988.

I further certify that at a meeting of the stockholders/directors of said corporation, duly called and held on April 10th, 2023 at its corporate office located at 7408 NE 113<sup>th</sup> Circle, Vancouver, Washington 98662, at which meeting a quorum was present and voting throughout, the following resolution was adopted by unanimous vote:

Resolved, that each of the following officers:

Brent Rotschy as President

Cornell Rotschy as Vice President / Secretary / Treasurer

Drew Rotschy as Vice President / Assistant Treasurer

Page Rotschy as Vice President

Shall be and is duly authorized to sign contracts for construction projects, and any and all documents relating thereto, individually and without limit as to size in dollars, including the signing of validation for bonds, from thereof perpetually.

Given under my hand and seal this 10th day of April 2023.

A handwritten signature in blue ink, appearing to read "Cornell Rotschy", is written over a horizontal line.

Cornell Rotschy  
Secretary

HEADQUARTERS OFFICE | 7408 NE 113<sup>th</sup> Circle | Vancouver WA 98662  
PASCO OFFICE | 2145 N Commercial Avenue | Pasco WA 99301  
(p) 360.334.3100 | (f) 360.334.3101 | [www.rotschyinc.com](http://www.rotschyinc.com)

WA# ROTSCHI\*1200A | OR CCB #95682  
ROTSCHY INC. IS AN EQUAL EMPLOYMENT OPPORTUNITY EMPLOYER



## ***APPENDIX A***

- ***5.3 – MINIMUM QUALIFICATIONS***

000468  
ROTSCHY LLC  
7408 NE 113TH CIRCLE  
VANCOUVER WA 98662

**CONSTRUCTION CONTRACTORS BOARD  
LICENSE CERTIFICATE**

LICENSE NUMBER: 239750  
EXPIRATION DATE: 03/10/2024  
ENTITY TYPE: Limited Liability

**CONSTRUCTION CONTRACTORS BOARD  
LICENSE CERTIFICATE**

ROTSCHY LLC  
7408 NE 113TH CIRCLE  
VANCOUVER WA 98662



*fold and detach  
along  
perforation*



**STATE OF OREGON  
CONSTRUCTION CONTRACTORS BOARD  
LICENSE CERTIFICATE**

This document certifies that:

ROTSCHY LLC  
7408 NE 113TH CIRCLE  
VANCOUVER WA 98662

is licensed in accordance with Oregon Law as  
Residential General Contractor & Commercial  
General Contractor Level 1

**LICENSE NUMBER: 239750**

EXPIRATION DATE: 03/10/2024

ENTITY TYPE: Limited Liability Company



## ***APPENDIX B***

- ***5.4.1 - COMPANY EXPERIENCE***





## CID Irrigation System Improvements 2019

Boardman, OR



### *Project Overview:*

This Project consist of installation of approximately 40,000 LF of 72 inch diameter pipeline, improvements to the existing booster pump station, construction of a new electrical building, installation of new electrical equipment, improvements to the existing control system, and other work.



### *Project Info:*

Owner: Columbia Improvements District  
Owners Address: 501 Columbia Ave NE  
Boardman, OR 97848  
Owners Contact Name: Robert Muller  
Contact Number: 1.541.481.9454  
Engineer: Anderson Perry  
Engineers Contact Name: Lucas Stigel  
Contract: \$8,467,870.25  
Start: 6/2019 Complete: 4/2020  
Supervisor: Hank Stigall  
Project Manager: Hans Schmeusser





## CID I-84 Carrier Pipe Crossing

Boardman, OR



### *Project Overview:*

Rotschy, Inc. removed approximately 370 feet of existing 72 inch diameter steel pipe with 310 feet of steel pipe installed inside of the existing 78 inch corrugated metal casing pipe and the furnishing and installation of approximately 370 feet of new owner supplied 72 inch diameter steel pipe with 310 feet of steel piped installed inside the 310 foot long, 78 inch corrugated metal casing pipe. Work also included furnishing all labor, materials, tools, equipment, and incidental required to construct a complete pipeline.

### *Project Info:*

**Owner:** Columbia Improvement District

**Contact:** Mark M

**Engineer:** Anderson Perry

**Contact:** Brett Moore

**Contract:** \$238,470.00

**Start:** January 2017 **Complete:** 2017

**Supervisor:** Arron Carrol

**Project Manager:** Michael McBride





## ECBID Pipe 2019-096

Warden, WA



### *Project Overview:*

Furnishing and installation of approximately 117 LF of 60" diameter steel pipe, the furnishing and installation of approximately 2,438 LF of 54" diameter steel pipe and the associated appurtenant work.

### *Project Info:*

**Owners Name:** East Columbia Basin Irrigation District

**Owners Address:** 55 North 8<sup>th</sup> Othello, WA 99344

**Owners Contact:** Jeremy Underdown

**Owners Phone Number:** 1.509.488.9671

**Engineers Name:** East Columbia Basin Irrigation District

**Engineers Address:** 55 North 8<sup>th</sup> Othello, WA 99344

**Engineers Contact:** Jon Erickson

**Engineers Phone Number:** 1.509.488.9671

**Original Contact:** \$1,251,921.54

**Final Contact:** \$1,256,831.51

**Start:** 11/1/2019

**Complete:** 8/20/2022

**Supervisor:** Troy McDaniels

**Project Manager:** Michael McBride





## Wallula Dodd Water Line Transmission

Burbank, WA

### *Project Overview:*

Construction of approximately 435 of 12-inch water line, 15,850 feet of 18-inch water line, 14,095 feet of 24-inch water line, and 2,280 feet of 30-inch water line, 460 feet of 36-inch casing, 800 feet of 18-inch utility casing, 6,250 cubic yards of excavation; 4,200 cubic yards of embankment compaction; valves and fittings, combination air/vacuum valve assemblies and manholes, blow off hydrants and drainage swales, restoration work; concrete splash pads, testing together with all other work as specified in the bidding documents. Also included additive and deductive alternatives pertaining to partially restrained pipeline and the installation of 10,100 feet of 2-inch PVC Conduit.



### *Project Info:*

Owners Name: Port of Walla Walla

Owners Address: 310 A Street Walla Walla, WA 99362

Owners Contact: Patrick Reay

Engineers Name: Anderson Perry

Engineers Address: 214 E. Birch Street Walla Walla, WA 99362

Engineers Contact: John Wellis

Engineers Phone Number: 1.509.529.9260

Original Contact: \$4,240,410.05

Final Contact: \$ 4,337,602.99

Start: 11/4/2019

Complete: 11/2020

Supervisor: Aaron Carrol

Project Manager: Darin Kysar





## PROJECT PORTFOLIO (OUR EXPERTISE)

### BUILDINGS

- **STAINLESS CABLE AND RAILING**

\$4,651,735.23 | Eric Reimer | Washougal, WA | Complete 2022

Construct 3 PEMB with associated civil sitework in the Port of Camas/Washougal business park for Stainless Cable and Railing



- **RIXIR SYSTEMS HEADQUARTERS**

\$4,810,204.00 | Rivco Development | Battle Ground, WA | Complete 2022

Construct concrete foundation, insulated PEMB shell and mezzanine structure.

- **COMMERCE CENTER BUILDING 18 – PEMB Design/Build**

\$4,991,533 | Port of Camas/Washougal | Completed May 2018

Rotschy constructed a 49,500-square-foot pre-engineered metal building (PEMB) at the Steigerwald Commerce Center industrial park for the Port of Camas/Washougal. Work on the PEMB included exterior finishes, insulated metal siding panels, insulated roof system, and interior MEP systems.



- **TERRACE INDUSTRIAL PARK – PEMB Design/Build**

\$5,000,000 | Synergy Resources, LLC. | Vancouver, WA | Completed October 2017

Rotschy teamed with Johansson Wing Architects on this design/build industrial and commercial development in east Vancouver. Work involved the design and construction of eight PEMB building shells ranging in size from 6,250 square feet to 7,500 square feet each, including exterior finishes and interior MEP systems.



## STRUCTURAL CONCRETE

### ▪ GRANT STREET PIER

\$12,314,432 | City of Vancouver | Vancouver, WA | Completed 2019

Rotschy constructed a 3,480 square-foot cable-stayed pier and plaza on the Columbia River in the City of Vancouver. This pier is the center piece of a future water front park. New construction involved a cofferdam, permanent ground anchors, structural concrete abutment supported on drilled shaft piles, backstay foundation supported on micro piles, MSE gabion walls, steel mast and cables, wood decking, railing, lighting, stone and concrete pavers, and terraced wood seating.



### ▪ VOIGHTS CREEK HATCHERY

\$9,683,000 | WDFW – Orting, WA | Completed August 2015

Rotschy constructed a new fish hatchery facility on Voight’s Creek that included an intake structure, fish ladder, rearing ponds, adult ponds, pollution abatement ponds, pre-engineered office, hatchery and feed-storage buildings, process piping (involving both pipe boring and pipe ramming), cofferdams, and generator pumps.

### ▪ WILLIPA RIVER BRIDGE

\$4,077,789 | WSDOT – Menlo, WA | Completed June 2014

Rotschy demolished an existing steel-truss bridge on SR-6 and replaced it with a prestressed concrete girder bridge. Work also included installation reinforced concrete drilled shafts, structural of guardrail, seeding and planting, reforestation of the project site.

## TREATMENT PLANTS AND RESERVOIRS

### ▪ 18<sup>TH</sup> AND KELLOGG RESERVOIR REPLACEMENT

\$15,080,320 | City of Kennewick, WA | In Progress

Rotschy is currently constructing a new 6.0-MG pre-stressed concrete reservoir that includes a mechanical mixer and underdrain collection system; a new concrete and CMU pump building that houses vertical turbine pumps, chlorine generation and injection systems, and surge tanks; a buried concrete inlet/outlet underdrain collection, suction valve and metering vault structure. Work also includes new offsite 30-inch diameter DI water pipeline.



▪ **WATER STATION 1 PHASE 2 – RESERVOIR AND SECURITY UPGRADES**

\$20,501,041 | City of Vancouver, WA | Compl,

Rotschy is currently constructing two new 4.0-MG pre-stressed post-tensioned concrete reservoirs, one new 1.0-MG welded steel standpipe, and improved site security and access. The project replaces two existing concrete water reservoirs and an elevated steel water tower, and includes; demolition, earthwork, utility relocations, large diameter water pipelines, drainage systems, roadways, paved pedestrian paths, tree removal, landscaping, site lighting, heavy duty security fencing, security cameras, and decorative features.



▪ **CASCADE RESERVOIR IMPROVEMENTS & WELL NO. 7**

\$18,846,724.60 | City of Gresham, OR | In Progress

Rotschy is currently rehabilitating an existing 4.0-MG welded steel reservoir. We will be constructing a new 6.0-MG prestressed concrete reservoir, along with a new well house. The project also includes the installation of approximately 11,750 LF of restrained ductile iron water piping in various diameters up to 42-inches.

▪ **WATER STATION 5 RESERVOIRS AND PUMP STATION**

\$25,080,080.84 | City of Vancouver, WA | In Progress

Rotschy is currently constructing two new 4.0-MG AWWA/ANSI D110 Type 1 concrete reservoirs; as well as a new pump station with vertical canned turbine pumps and adjustable frequency drives. Other work includes electrical upgrades to include back up power and an upgraded control system, various site improvements for access, security, lighting, landscaping, and storm water treatment, phased demolition of the existing reservoirs and pump station



▪ **PARADISE POINT WATER SYSTEM**

\$9,114,057 | Clark Public Utilities | Ridgefield, WA | Completed 2020

Rotschy constructed an 11,552-square-foot water treatment building and associated equipment, three steel storage reservoirs, water yard piping and appurtenances, grading and site improvements, erosion control, street improvements, paving, landscaping, storm drain system, electrical system, control system, and communication system.

▪ **WASTEWAY 5 RE-REGULATION RESERVOIR**



\$14,699,160 | RID – Sunnyside, WA | Completed 2017

Rotschy constructed a 1,600-acre-foot geomembrane-lined re-regulation reservoir. New construction included structural concrete (spillway, ramp flume, canal inlet and outlet, and pump wet well structures), box culvert road crossing, storm water drainage, pump station building, regulation pumps and piping, and a power transformer substation.

---

▪ **SLOW SAND FILTER TREATMENT PLANT**

\$5,766,978 | City of Camas, WA | Completed March 2016

Rotschy constructed a new slow-sand filtration treatment plant and administration building for the City of Camas. Construction included two concrete filter basins, roughing filter basin, filter gallery, chemical storage and injection room, finished office spaces, and general storage and work areas.

---

▪ **WASTEWATER TREATMENT FACILITY**

\$7,142,500 | City of Toledo, WA | Completed May 2015

Rotschy constructed a new wastewater treatment plant for the City of Toledo near the Cowlitz River. New construction included an influent pump station and force main, a wastewater treatment plant building, and an effluent pipeline and river outfall. The new wastewater treatment plant included headworks, oxidation ditch, secondary clarifiers, UV disinfection, effluent filtration, effluent sludge drying beds, plant drain pump station, and associated plumbing, HVAC, electrical, and controls work.

---

▪ **THOMPSON HILL ZONE 4 RESERVOIR AND BOOSTER STATION**

\$4,668,245 | City of Kennewick, WA | Completed October 2015

As the prime contractor on this job, Rotschy constructed 3.0-MG prestressed concrete reservoir and an aboveground booster station building complete with inline centrifugal pumps and a chlorine generation and injection system. New construction also included mechanical piping, HVAC, landscaping and irrigation, access road construction, site fencing and associated utilities.

---

## UTILITIES



▪ **WALLULA DODD WATER SYSTEM WATER LINE TRANSMISSION & DISTRIBUTION MAINS**

\$4,325,485.00 | Port of Walla Walla – Wallula, WA | Completed 2020

Rotschy constructed approximately 435 feet of 12-inch water line, 15,850 feet of 18-inch water line, 14,095 feet of 24-inch water line, and 2,280 feet of 30-inch water line; 460 feet of 36-inch casing, 800 feet of 18-inch utility casing; 6,250 cubic yards of excavation; 4,200 cubic yards of embankment compaction; valves and fittings; combination air/vacuum valve assemblies and manholes; blow off hydrants and drainage swales; restoration work; concrete splash pads.

---

▪ **EAST LOW CANAL LIND COULEE SIPHON NO. 1 AND SIPHON NO. 2**

\$13,916,327 | ECBID – Warden, WA | Completed May 2016

Rotschy constructed two siphon barrels on the East Low Canal near the Lind Coulee. The siphons were 1,885 and 2,592 feet long, respectively. Construction included removal





and control of water, diversion and care of Lind Coulee, siphon trench excavation; monolithic cast-in-place concrete; corrosion protection and monitoring; and concrete blowoff structures. Work also involved detouring, and reconstructing Lind-Warden Road.

---

▪ **COWLITZ COUNTY HEADQUARTERS LANDFILL LEACHATE TRANSMISSION SYSTEM**

\$7,347,346 | Cowlitz County, WA | Completed November 2014

Rotschy installed approximately 78,000 feet of eight-inch HDPE leachate forcemain using open-trench and horizontal-drilling methods. The leachate forcemain originated at the Headquarters Landfill and terminated at the Public Works facility in Longview, WA. Work included air-release valve stations, pigging stations, leachate pump station, leachate pond modifications, and road surface restoration.

---



▪ **WATER BUREAU INTER-TIE**

\$8,568,096 | Portland Water Bureau – Sandy, OR | Completed May 2014

Rotschy, as the prime contractor, constructed a 1.0-MG partially buried circular prestressed concrete reservoir, a 1.0-MGD potable water pump station, and a 1.5-MGD packaged pump station. Work also included 13,190 feet of 24-inch and 13,800 feet of 19-inch transmission mains, and electrical instrumentation, controls and telemetry systems.

---



## ***APPENDIX C***

- ***5.4.2 – PERSONNEL EXPERIENCE***



## KOLTON DEFORD

Land Use Planner/Permitting Specialist

*Kolton DeFord has 7 years of experience working with land development processes and permitting in both Commercial and Residential fields. Experience includes subdivisions from conception to completion of the platting process and Commercial site plans and building from conception to final occupancy. Experienced in permitting processes for a variety of supporting permits required for land development activity. Kolton is also experienced in researching the potential requirements of new permitting circumstances including critical areas and unique or unusual project parameters. Kolton's experience has given him a unique look at a diverse range of land use planning problems that have required a wide range of creative solutions.*

*Kolton joined Rotschy Inc in 2021 to support ongoing development activity and bolster the company's ability to develop commercial site plans and permit new buildings in-house and aid in supporting permits required for residential development.*

### PREVIOUS WORK EXPERIENCE

<b>Rosenbaum Financial</b> Intern	2012-2014
<b>Kessi Consulting</b> Land Use Planner	2016-2021
<b>Rotschy Inc</b> Land Use Planner/Permitting Specialist	2021-Present

### Education

*Associate of Arts degree from Clark College, Vancouver, WA. 2012*  
*Bachelor of Science Degree- Real Estate, Portland State University Class of 2014*

### PROJECT EXPERIENCE

- Tyson Foods Hot Water Storage Tank & Pump Station - \$ 1,735,760.00** *In progress*  
Construction of a hot water tank system and supporting structures. Kolton's role included permitting and coordinating communication with the County.
- Lot 6 Commercial Building -** *In progress*  
Construction of a 9000 square foot commercial building. Kolton's role included permitting and communication with Clark County, coordinating with 3<sup>rd</sup> party consultants, and assessing required documentation needed to complete the permitting process.
- Tractor Supply Ridgefield -** *In progress*  
Construction of a new Tractor supply location in Ridgefield, Washington. Kolton's role included coordinating with 3<sup>rd</sup> party architects, engineers, and developers and permitting of all structures.



**Lacamas Tech Center -**

***In progress***

Construction of 6 commercial buildings totaling 116,000 square feet located in Business Park zoning in Camas, WA. Kolton's role included permitting and planning from project conception to final occupancy. Work included establishing preliminary design approval criteria, pre-application, site plan approval, architectural approval, boundary line adjustment, and supporting permitting including road closures and demolition permits]. Continuing work includes aiding with the final occupancy process and tenant improvement permits. Phase 1 to be completed 2023.

**Highway 14 164<sup>th</sup>- I-205 Auxiliary Lanes -**

***In progress***

Construction of Auxiliary lanes on the North side of Washington Highway 14 between NE 164<sup>th</sup> and Interstate 205. Kolton's role included supporting permitting including temporary use permits for staging area required to efficiently cast sound barrier concrete walls.

**Curtain Creek Meadow Subdivision -**

***In progress***

Project includes a subdivision and creation of new residential neighborhood. Kolton's role included final platting coordination, coordinating plan approval from local utilities, and a traffic impact fee credit application.

**Weibold Development -**

***Completed 2020***

Commercial/industrial site plan approval for 9 lots including the Rotschy INC Headquarters, a gas station, and 4 commercial pads. Kolton was involved in this project from pre-application to final occupancy, his duties included creating application and coordinating all requirements with 3<sup>rd</sup> party consultants, engineers, and property owners. Work included pre-application, site plan approval, archeological approval, critical areas permitting, flood plain review, creation of new signalized intersections with 3<sup>rd</sup> party design, and frequent communication with Clark County throughout the approval process.

**Synergy Industrial Park -**

***Completed 2022***

Project included site plan approval, construction of 2 industrial buildings and the associated tenant improvements. Kolton was involved in this project from conception to completion. His role included pre-application, site plan application, permitting tenant improvements, and aiding in the final occupancy process. Project was also faced with unique circumstances that required an outsized amount of time dedicated to approvals as the location was annexed by the City of Vancouver from Clark County mid-way through the process, meaning that approval work was divided between jurisdictions with unique requirements imposed Kolton was required to coordinate.

**Tri-Mountain Industrial Park -**

***Completed 2022***

Construction of a commercial/industrial park including 5 buildings and associated site improvements. Kolton's role included building permits, plumbing and mechanical permits, and fire Marshall permitting for all buildings as well as coordinating final occupancy approval with the City of Ridgefield for all buildings.

**Velvet Acres Subdivision -**

***Completed 2018***

Project included approvals needed to construct a residential subdivision in Eastern Clark County. Kolton's role included putting together all applications for subdivision approval up to the point of construction. These included pre-application, application for subdivision, aiding in the public hearing process including responses to concerns presented by the county, and early grading permits.



***Cloverhill PUD -***

***PUD approval in 2017***

Approval of a Planned Unit Development across 75 acres including preliminary approval to subdivide for over 250 homes of all types from narrow lot townhomes to large lot luxury homes located in Ridgefield, WA. Kolton's role in this large multi-phase project was to coordinate permitting activity, attend hearings, coordinate communication with the City of Ridgefield, WA, build and submit applications, and aid in determination of requirements.

***University Park Subdivision -***

***Completed 2020***

Project included permitting of 9 lot short plat with numerous critical areas hazards. Kolton's roles included coordination of project requirements, coordinating with consultants, research into similar approved projects, permitting critical areas plans and flood zone application for an access road, permitting an alternative water source, and all associated permitting for short plat approval.



**Darin Kysar**  
Project Manager

---

*In 1995, Darin started working at Rotschy, Inc. as a general laborer in the field. While in the field, he worked on a wide variety of projects in different roles, including equipment operator, foreman, and field superintendent. In 2008, in recognition of his work ethics and capabilities, Darin transitioned into a project management role, and in this capacity, he has been instrumental to Rotschy, Inc.'s success in the public work sector.*

---

**EDUCATION**

Howard Junior Senior High School, Howard, SD – 1995

**WORK EXPERIENCE**

***Rotschy, Inc. – Project Manager*** ***2008 – current***

In his current position, Darin has successfully managed many of the company's largest public works transportation jobs. His ability to coordinate construction with owners, permitting agencies, consultants, subcontractors, and other stakeholders is demonstrated by each project he has managed; his projects have been consistently completed within budget and on schedule. As a project manager, Darin leads construction progress meetings, tracks field productions, procures materials and subcontractor services, and negotiates project changes with the owners.

***Rotschy, Inc. – Field Laborer, Equipment Operator, Foreman, Superintendent*** ***1995 – 2008***

Prior to his project management role, Darin worked in the field at Rotschy, Inc as a general laborer and an equipment operator on a wide variety of projects. He installed utilities of all types, constructed public road projects, and worked on numerous land clearing and excavation jobs.

**PROJECTS MANAGED**

***46<sup>th</sup> Ave Ocean Beach Hwy to Olympia Way-\$4,689,632.85*** ***In Progress***

This Contract provides for the Improvement of \*\*\* 46<sup>th</sup> Avenue from Ocean Beach Highway to the Consolidated Diking District #1 Cutoff Slough. This project constructs roadway including excavation, embankment construction, paving with HMA, curb, sidewalk, curb ramps, stormwater collection/conveyance/ treatments, sanitary sewer, water main, signing, striping, and landscape improvements\*\*\* and other work, all in accordance with the attached Contract Plans, these Contract Provisions, and the Standard Specifications.

***Groundwater Development Project Package No 6 - \$6,822,236.40*** ***In Progress***

Schedule A: Wellhouse construction including civil, architectural, structural, mechanical, electrical, instrumentation and controls, and landscaping.

Schedule B: Raw water transmission main piping and appurtenances, various diameter ductile iron pipe (3650LF).

Schedule B: Distribution system piping and appurtenances, various diameter ductile iron pipe (825 LF).

***SR 503/ SR 502 Intersection Improvements-\$4,401,906.69*** ***In Progress***

Improvement of the SR 503 (NW and SW 10th Avenue) and SR 502 (W Main Street) intersection for



provision of right turn lanes and additional left turn lanes. The Project includes clearing and grubbing, roadway excavation, storm sewer conveyance, treatment and detention, HMA paving, erosion control, curb and gutter, refuge island construction, sidewalk, traffic control, pavement marking, signing, traffic signal system, illumination and other work, all in accordance with the Contract Plans, Contract Provisions, and the Standard Specifications.

**SR 14: I-205 to SE 164<sup>th</sup> Ave. Auxiliary Lanes-\$17,122,823.75** ***In Progress***

Improvements to SR 14 by constructing a noise barrier wall, concrete barriers, overhead sign structures, paving, landscaping, drainage, storm sewer, Intelligent Transportation System (ITS), traffic control, and other work.

**CRWWD 20<sup>th</sup> Ave. Trunk Repair-\$4,387,319.05** ***In Progress***

Construction of approximately 3,700 feet of 30-inch diameter trunk sewer and abandoning adjacent existing sewer line from NE 152nd Street to the Legacy Pump Station on NE 139th St.

**Airport Reservoir and Booster Pump Station- \$10,565,626.00** ***In Progress***

This job consists of furnishing all labor, materials and equipment necessary for the construction of a 2.0 million gallon aboveground welded steel reservoir; a 4,500 gallon per minute firm capacity potable water pump station; approximately 5,000 lineal feet (LF) of 24-inch diameter transmission main and 2,500 LF of 18-inch diameter transmission main; complete electrical, instrumentation, controls and telemetry systems; and associated mobilization, site work and appurtenances. The work also includes water connections into existing systems.

**Mid-Willamette Valley Intermodal Center- \$11,079,570.12** ***In Progress***

Construction of paved truck queuing and check-in entrance area, and an intermodal yard capable of handling both domestic and international containers. Features include a 140,000 SF gravel container yard to stage/store containers and refrigerated containers as well as chassis staging and storage, paved loading and unloading area, service roads, maintenance areas, and over 16,500 LF of rail track with compressed air system to support train assembly. Intermodal rail yard to stage/store containers and refrigerated containers as well as chassis staging.

**Steigerwald Floodplain Restoration-\$15,545,589.50** ***In Progress***

The purpose of the Steigerwald Project is threefold: (1) to restore hydrologic connectivity between Gibbons Creek, the Columbia River, and adjacent floodplain habitats within the Steigerwald Lake National Wildlife Refuge (Refuge); (2) to reduce internal flooding and operations costs; and, (3) to improve recreation opportunities at an urban wildlife refuge visited by as many as 90,000 people per year. Work generally consists of the following:

- Remove approximately 11,600 linear feet of the Port's existing levee system;
- Construct three test fills and assist with installation of Owner-provided test fill monitoring equipment;
- Construct two setback levees, including a flood wall, closure structure, closure structure storage facility, levee maintenance roads, wave break overbuild, vehicle turn arounds, and other associated infrastructure;
- Perform geotechnical testing to ensure integrity of levee prism, including required materials testing laboratory and staff to keep pace with materials testing requirements;
- Remove a diversion structure, elevated canal, fish ladder, maintenance road, and several culverts and water control structures from within the floodplain;
- Construct four new floodplain channels and excavate new habitat areas;



- Isolate, dewater, and remove fish from in-water work areas;
- Realign Gibbons Creek, construct stream features, install scour protection at the State Route 14 (SR 14) bridge, and regrade floodplain;
- Furnish temporary traffic control signage, message board, temporary signal, flaggers, and spotters;
- Reconstruct / raise approximately 1,600 linear feet of State Route 14 (maximum of three vertical feet);
- Furnish and install wood habitat structures;
- Seed disturbed areas;
- Remove existing fencing from within the Work area and install various types of fencing, gates, and railings;
- Remove, stockpile, and reinstall existing interpretive/trail features;
- Construct 2.9 miles of new trail/access road, including two at grade crossings, three new prefabricated bridges, and connections to existing trails;
- Relocate and landscape the Refuge's existing parking lot and associated infrastructure;
- Manage an area of low-level contaminated soil, which shall be disposed onsite; and,
- Establish and maintain temporary access routes, staging areas, disturbance limits, and erosion control

**Water Station 5- \$25,080,080.84**

***In Progress***

This project includes furnishing and installing; two new 4-million gallon AWWA/ANSI D110 Type I concrete reservoirs; a new pump station with vertical canned turbine pumps and adjustable frequency drives; electrical upgrades to include back up power and an upgraded control systems; various site improvements for access, security, lighting, landscaping, and stormwater treatment, phased demolition of the existing reservoirs and pump station with strict adherence to construction sequencing that will allow the site to remain operational during construction.

**Cascade Reservoir Improvements & Well No. 7 - \$18,846,724.60**

***In Progress***

The work consists of furnishing all labor, materials, and equipment necessary for the rehabilitation of an existing 4-million-gallon welded steel reservoir; construction of a new 6-million-gallon prestressed concrete reservoir; construction of a new wellhouse; installation of approximately 11,750 LF of restrained ductile iron water piping (various diameters up to 42-inch), and associated site improvements, electrical and controls.

**Wallula Dodd Concrete Reservoir-\$6,127,918.75**

***Completed 2021***

The work includes the design and construction of a nominal 6.2-million-gallon prestressed wrapped poured in place concrete reservoir tank and associate, installation of approx. 1,400 LF of 24 and 30 inch diameter water mains, approx. 830 LF of 8, 12 and 30 inch dia gravity drain system and associated manholes, ring drain system, fencing and gravel surfacing and misc. work

**Wallula Dodd Water Line Transmission-\$ 4,240,4103.05**

***Completed 2020***

Includes construction of approx. 435' of 12" water line, 15,850' of 18" waterline, 14,095 ft. of 24-inch waterline, and 2,280 ft. of 30-inch water line, 460ft of 36 inch casing, 800 ft. of 18inch utility casing, 6250 cubic yards of excavation, 4,200 cubic yards of embankment compaction, valves and fittings, combination air/vacuum valve assemblies, and manholes. Blow off hydrant and drainage swales, restoration work, concrete splash pads, testing, together with all other work.

**SR503 Median Barrier-\$1,788,863.17**

***Completed 2021***

SR503 from MP 4.58 to MP 8.09, by installation type F concrete median barrier, impact attenuator, permanent signing, drainage, channelization within project limits, wetland habitat enhancement through selective clearing.





**Water Station 1 Phase. 2 - \$18,912,400.00**

**Completed July 2022**

This Project consist of 2 new 4-million-gallon prestressed post tension concrete reservoirs, a new 1-million-gallon welded steel standpipe, and improved site security and access. Replacement of 2 existing concrete water reservoirs and elevated steel water tower, demo, earthwork, utility relocations, water pipelines, drainage systems, roadway, paved paths, tree removal, landscaping, site lighting, heavy duty security fencing, decorative features, and many others.

**152<sup>nd</sup> Ave Reservoir - \$ 11,356,914.20**

**Completed 2020**

Construction of a partially buried 6.0 Million gallon (MG) Prestressed concrete reservoir, a fully buried, cast in place concrete vault structure and associated electrical control building of concrete masonry unit and wood framed roof construction, design and installation of temporary construction shoring systems as required for construction of the proposed reservoir and valve vault structures; furnish and install buried storm water detention facility, site clearing including tree cutting, and grading, and earthwork at reservoir site and adjacent utility easements, excavation for and backfilling of above components as required for a complete installation, furnish and install approximately 3,000 LF of Class 52 restrained ductile iron water main, 36 inch and 24 inch diameter sizes, connect the new water mains to existing main lines including transmission and reservoir site connections, abandonment of existing water main and restoration of work site area to original or better conditions, including grading, temporary and permanent paving, erosion control and other measures as required.

**Roosevelt Regional Landfill- \$ 4,163,193.00**

**Completed 2019**

Construction of the project included excavation and subgrade preparation, placement of embankment, soil stockpiling, berm construction, manufacture, and placement of drainage aggregate over geosynthetics, HDPE Pipe installation, excavation and backfilling geosynthetics anchor trenches, and potential misc. construction.

**NE 119<sup>th</sup> St East, NE 87<sup>th</sup> Ave to NE 112<sup>th</sup> Ave-\$11,060,454.70**

**Completed 2019**

This project is to widen the roadway two lanes to the standards of a four lane minor arterial which includes, center left turn lanes, sidewalks and bike lanes. Water lines, sewer lines installation and railroad crossing signals.

**North Shore Sewer Transmission System-\$ 9,665,032.10**

**January 2018**

Improvements for the city of Camas, sewer and water system through installation of approximately 39,000 feet of 6" and 8" diameter HDPE force main pipes, approx. 2,200' of 12 " and 18" diameter PVC gravity sewer pipes, two new sewer pumping stations, modifications to a sewer pumping station constructed by others, a remote odor control facility, a 150 ft. long pedestrian bridge, and approx. 10,000 ft. of 12" diameter ductile iron water pipe to serve development of the N. shore Area.

**Camp Withycombe sanitary Sewer Repairs- \$1,645,893**

**November 2017**

Project was repairing failing sections of the sanitary sewer lines servicing the logistical support areas of Camp Withycombe by replacing old, leaking lines with a new PVC lines. Project also repaired and replaced manholes, and cap and seal old, abandoned lines.

**Walnut Street-\$4,131,877**

**December 2017**

Construct retaining walls. Construct storm sewer system and water quality facilities. Construct sanitary sewer system. Construct potable water system. Construct HMAC paving. Construct curb and sidewalk.



Install permanent striping and signing. Install traffic signal and loop detector modifications. Install illumination system. Install landscaping.

***WSDOT I-5 to Battle Ground, Add Lanes, Stage 2 – \$27,544,360***

***November 2017***

Darin is managing this WSDOT-let project which widened SR-502 from two lanes to a four-lane divided highway between Battle Ground and Dollars Corner. Major elements of work included clearing and grubbing, grading, subgrade improvements, installing storm sewer, surfacing, constructing a bridge and three precast reinforced concrete three sided structures, constructing a structural embankment with concrete columns, installing median barrier, guardrail, pavement markings, traffic signals, illuminations, signing, intelligent transportation system, erosion control, traffic control and associated work.

***Bolton Reservoir Replacement-\$8,908,069***

***Completed 2017***

Schedule A: New 4.0MG circular restressed concrete reservoir, site work including demo of 2.5MG reservoir, earthwork, site grading, foundation, water and storm improvements, access road, fencing, landscaping, electrical, instrumentation, controls, telemetry. Schedule B: Improvements to existing Bolton Pump Station includes new roof, relocating 200HP vertical turbine pump, install 2 new pump controls valves, surge valve, 100HP vertical turbine pump, with associated work. Schedule C: install approx. 3,100lf of 24in potable water main. Schedule D: approx. 3,800lf of road reconstruction including road widening, curb sidewalks, drainage improvements, retaining walls, asphalt paving, pavement striping and landscaping.

***Clark County NE 119<sup>th</sup> Street – NE 72<sup>nd</sup> Ave to NE 87<sup>th</sup> Ave – \$19,369,388***

***Completed 2016***

This project, let by Clark County, widened NE 119th Street from two lanes to five lanes, including a center turning lane, bicycle lanes, and sidewalks. New construction also included intersection improvements and new traffic signals at NE 72nd Avenue and NE 87th Avenue as well as installation of storm water systems, water and sewer lines, fish-passage culvert, and wetland mitigation. Installation of the utilities was facilitated by a combination of deep-well and well-point dewatering systems.

***City of Camas Slow Sand Filter Treatment Plant – \$5,766,978***

***Completed 2016***

Rotschy constructed a new slow-sand filtration treatment plant and administration building for the City of Camas. Construction included two concrete filter basins, roughing filter basin, filter gallery, chemical storage and injection room, finished office spaces, and general storage and work areas.

***City of Camas Water Transmission Main – \$2,132,642***

***Completed 2014***

This project involved the installation of approximately 17,770 feet of 12-inch and 18-inch ductile iron water transmission main. Work also included a prefabricated pressure-reducing valve station, air-relief valve vaults, hydrant assemblies, and connections to existing systems.

***City of Battle Ground West Main Street Alignment – \$4,180,121***

***Completed 2014***

Improvements to West Main Street in the City of Kelso included building demolition, grading, storm sewer pipe installation, waterline and sanitary sewer replacement, curb, gutter and sidewalk construction, rain garden construction and planting, paving with HMA, erosion control, signal installation and modification, illumination, interconnect systems, pavement marking, signing, planting, irrigation, and other work.

***Portland Water Bureau Intertie – \$8,568,096***

***Completed 2013***

This project involved the construction of a 1.0-MG partially buried circular prestressed concrete reservoir and two potable water pump stations (1.0-MG and 1.5-MG) as well as 13,190 feet of 24-inch



diameter and 13,800 feet of 18-inch diameter transmission mains. Work also included complete electrical, instrumentation, control and telemetry systems and water, sewer, and storm drain connections.

***Clark County Timmen Road – \$4,098,775***

***Completed 2013***

This Clark County-let project included roadway overlay for two travel lanes and construction of a northbound right-turn lane on Timmen Road and a westbound left-turn lane on La Center Road. Construction also involved limited guardrail updates, crushing and recycling the existing PCC panels for roadway base, and installation of 24-inch waterline.

***Clark County NE 10<sup>th</sup> Avenue from Ne 141<sup>st</sup> Street to NE 149<sup>th</sup> Street – \$2,284,051***

***Completed 2013***

Rotschy widened NE 10<sup>th</sup> Avenue between NE 141<sup>st</sup> Street and NE 149<sup>th</sup> Street to provide two travel lanes plus a center-turn lane, bicycle lanes, and sidewalks. Work also included installation of storm water collection, conveyance, and treatment systems and installation of sewer lines, permanent signing, and roadway striping.

***Clark County NE 88<sup>th</sup> Street – \$11,631,783.00***

***Completed 2013***

Widen NE 88th St (NE Hwy 99 to NE St Johns Road) from two lanes to three lanes, including bicycle lanes and sidewalks. Storm water collection and treatment systems, retaining walls, water line and sewer lines installations; also, traffic signal modifications and installations of street lighting in areas.

***Chapel Hill Boulevard Subdivision- \$597,047***

***Completed 2013***

***City of Battle Ground SE Grace Ave Phase 1 – \$4,288,308***

***Completed 2012***

Road improvements project including curb & gutter, sidewalk, planter strips on either side of the road; rock, asphalt placed along the length of the project to create travel and bike lanes. Sanitary, storm and water utilities also placed on the project.

***WSDOT NE 134<sup>th</sup> Street Interchange (I-5 and I-205) Stage 1 – \$19,949,910***

***Completed 2012***

Improvement of I-5/I-205 in Clark County included clearing, grubbing, grading, drainage, surfacing, planning, constructing retaining and sound walls, installing illumination and signal systems, installing bridge and permanent signs, building storm ponds, a storm water pump station, landscaping, erosion control, offsite mitigation site and associated work.

***Clark County Salmon Creek Interchange – \$11,583,681***

***Completed 2011***

Project: Prep work for future bridge to be put in. Includes widening of roads, roadway excavation of 37,000cy, rock of 18,300cy, paving of 18,400ton, building walls, installing a storm system including ponds, new traffic signals, pervious concrete pavement, irrigation system, illumination system

***Sunnyside Valley Irrigation District Milepost 37.10 Reservoir – \$5,213,650***

***Completed 2011***

Project was to build a PVC membrane lined irrigation water storage reservoir with approximately 300 acre-feet of capacity. The design allows for water inflow from the adjacent canal through a motorized slide gate. Additional reinforced concrete structures include a ramo flume, inlet/Wasteway structure and a check structure. Work included a significant amount of earthwork, concrete structures, steel and HDPE pipe, PVC lining and electrical work. Use of the existing raw rock included overburden excavation and stockpiling and material screening, crushing, loading, hauling and stockpiling.

***City of Long Beach Water Treatment Plant - \$4,003,930***

***Completed 2011***



Construct new 1.5MGD water treatment plant. New building, electrical work, power generator, HVAC system, chemical feed & storage systems, raw & finished water instrumentation, associated process piping, instrumentation control and telemetry, clear well contact chamber, yard piping, raw water transmission main, all earthwork and site work. Included logging, clearing, grading, excavation, detention and infiltration ponds. Also included modifications to existing water tank site.

**Clark Public Utilities Fruit Valley Transmission Main – \$1,204,856** **Completed 2010**

Project: Connects the South Lake Water Treatment Plant, to the existing water system. The project includes 4,570 feet of 30" ductile pipe and 910 feet of 24" and smaller piping and all the related fittings and appertencies. Also in the scope is 287 feet of 48" bore under the railway. Currently, the entire 30" ductile main has been installed including the bore. Only the smaller piping and surface restoration remains. Rotschy, Inc. has self-performed all of the work except the paving and boring, which has been subcontracted.

**Clark Public Utilities South Lake Well Field Construction– \$3,676,215** **Completed 2010**

Project consisted of a 22 acre site: The project consists of a treatment building, two well buildings, yard piping, landscaping, grading and paving along with the installation of owner provided equipment. The treatment building is a 7420 sf CMU building, which includes 1640 sf of finished office and equipment rooms, a 5780 sf filter room and a mezzanine. An owner supplied, contractor installed, hypochlorite and filter system treat the water. The site has several hundred feet of bio filter swales and storm piping, several acres of site grading and paving and other site improvements.

**ODOT US 197 Burnham Ave to 3<sup>rd</sup> Street – \$2,231,821** **Completed 2009**

Street reconstruction: grading, paving, drainage, illumination

**City of Vancouver Ellsworth Pump Station - \$3,265,269** **Completed 2009**

Construction of a new 3200 SF building, 7500 gpm potable water pump station, including pumps and valves, together with associated site work which includes site grading, erosion control, new asphalt paving, concrete walkways around new pump station, electrical work, and instrumentation. Also includes the construction of approx. 300ft of new 24-inch suction pipe and approx. 1400 ft. of 24-inch transmission main (including valves and other various appurtenances), 160 ft. of 24-inch storm drain piping, appurtenances, a storm water quality treatment facility and other work to complete the project.

**Baker Way Pump Station-\$490,377** **Completed 2008**

Installation of two owner supplied 150 horsepower vertical turbine pumps in an existing pump station, supply and install two 36" ductile discharge pipelines each 300' into a rip-rap outfall in the river including fittings, air releases, etc., widen access road, misc. excavation and embankment associated with the installation of the pipelines.

**Camas Wells No.13-\$1,034,138** **Completed 2008**

The Well No. 13 project consisted of the installation of a deep well turbine pump (furnished by Owner) into an existing casing plus the installation of site piping, CMU building, onsite hypochlorite generation system, caustic soda feed system, sodium fluoride feed system, and electrical for a complete installation.

**R170 Landslide Area Canal Relocation-\$641,517** **Completed 2008**

Project consisted of demolition, pond, embankment, irrigation piping and concrete canal.



**USBR Canal Realignment-\$6,385,911**

**Completed 2008**

Project was a realignment of existing canal and irrigation improvements.

**EXPERIENCE DETAILS AS SUPERINTENDENT**

**99<sup>th</sup> Street Park and Ride – \$3,178,077**

**Completed 2007**

Darin managed construction of a 610-vehicle parking lot, including a large storm water conveyance and detention system.

**Thomas Jefferson School Offsite Storm water Modifications – \$505,867**

**Completed 2007**

This project involved offsite storm water system improvements and modifications.

**Felida Meadows Substation – \$402,371**

**Completed 2007**

Work on this project included clearing, grading, excavation, underground utilities, and adjacent road improvements.

**Port of Vancouver Dredge Disposal Site – \$855,939**

**Completed 2005**

As the superintendent on this project, Darin managed field labor, equipment, and materials in the process of building an earthen dike around 80 acres for future containment of dredge disposals.

**Terrace Heights Transfer Station – \$1,038,662**

**Completed 2005**

This project involved excavation and grading of a portion of the Yakima County Terrace Heights landfill and installation of a storm system conveyance system and other miscellaneous items.

**SE Mill Plain Extension to SE 192<sup>nd</sup> Ave (Phases 3B, 4, and 5) – \$3,282,014**

**Year Completed: 2005**

Mill Plain Boulevard was extended easterly to the intersection with SE 192<sup>nd</sup> Avenue. This road project, completed for the City of Vancouver, included new underground utilities, relocation of existing utilities, and pedestrian improvements.



## KERRY HOMOLA

### PROJECT ENGINEER

*Kerry started working at Rotschy, Inc as a project superintendent in 2011. In 2016 Kerry was recognized for his hard work and outstanding work ethic and became a Project Engineer. With 30+ years of construction experience and 15 years of project management experience, Kerry has been instrumental in streamlining our quality control process for many projects. His routine responsibilities include the many daily management tasks required for our public works projects such as submittal documents, change orders, requests for information, material purchase orders, subcontractor agreements, and final as-built drawings.*

### WORK EXPERIENCE

#### **ROTSCHY INC**

2011-PRESENT

*Current Position: Project Engineer*

*Foreman/ CECSL / Superintendent/ Assistant Project Manager*

*In his current position as project engineer, Kerry works directly with the project management team, owner, design professionals, and field personnel. During the 10 years at Rotschy, projects have ranged from large Private, Commercial, & Public works projects, heavy civil, wastewater, water treatment, and DOT.*

*Duties included: Project correspondence, submittals, RFI's, scheduling, material/supplier procurement, subcontractor coordination, and project closeout.*

#### **Custom Masonry Inc.**

2006-2011

*Position: Project Manager.*

*Foreman/ Superintendent/ Assistant Project Manager (Large Private, Commercial, & Public works project, heavy civil, waste water, water treatment, DOT. Working directly with Architects, Engineers, General Contractors, Project Management Teams and Field crews)*

#### **Massie Masonry Inc.**

1995-2006

*Position: Foreman.*

*Mason/ Stone Mason/ Foreman (Large private, commercial, & Public works projects, schools, waste water, water treatment, DOT. Working directly with General Contractors, Project Management and Field Crews.)*

#### **Master Craft Masonry**

1988-1995

*Position: Mason/ Stonemason.*

*Kerry began working in the construction field out of high school, apprenticing with his father in masonry, and working as a journeyman mason on residential and commercial projects.*

### EXPERIENCE AS PROJECT ENGINEER/ QUALITY CONTROL MANAGER

**46<sup>th</sup> Ave Ocean Beach Hwy to Olympia Way-\$4,689,632.85**

***In Progress***

This Contract provides for the Improvement of 46<sup>th</sup> Avenue from Ocean Beach Highway to the Consolidated Diking District #1 Cutoff Slough. This project constructs roadway including excavation, embankment construction, paving with HMA, curb, sidewalk, curb ramps, stormwater collection/conveyance/ treatments, sanitary sewer, water main, signing, striping, and landscape improvements and other work.



**Groundwater Development Project Package No 6 - \$6,822,236.40** **In Progress**

Schedule A: Wellhouse construction including civil, architectural, structural, mechanical, electrical, instrumentation and controls, and landscaping. Schedule B: Raw water transmission main piping and appurtenances, various diameter ductile iron pipe (3650LF). Schedule Ba: Distribution system piping and appurtenances, various diameter ductile iron pipe (825 LF).

**SR 503/ SR 502 Intersection Improvements-\$4,401,906.69** **In Progress**

Improvement of the SR 503 (NW and SW 10th Avenue) and SR 502 (W Main Street) intersection for provision of right turn lanes and additional left turn lanes. The Project includes clearing and grubbing, roadway excavation, storm sewer conveyance, treatment and detention, HMA paving, erosion control, curb and gutter, refuge island construction, sidewalk, traffic control, pavement marking, signing, traffic signal system, illumination and other work, all in accordance with the Contract Plans, Contract Provisions, and the Standard Specifications.

**SR 14: I-205 to SE 164<sup>th</sup> Ave. Auxiliary Lanes-\$17,122,823.75** **In Progress**

Improvements to SR 14 by constructing a noise barrier wall, concrete barriers, overhead sign structures, paving, landscaping, drainage, storm sewer, Intelligent Transportation System (ITS), traffic control, and other work.

**CRWWD 20<sup>th</sup> Ave. Trunk Repair-\$4,387,319.05** **In Progress**

Construction of approximately 3,700 feet of 30-inch diameter trunk sewer and abandoning adjacent existing sewer line from NE 152nd Street to the Legacy Pump Station on NE 139th St.

**Airport Reservoir and Booster Pump Station- \$10,565,626.00** **In Progress**

This job consists of furnishing all labor, materials and equipment necessary for the construction of a 2.0 million gallon aboveground welded steel reservoir; a 4,500 gallon per minute firm capacity potable water pump station; approximately 5,000 lineal feet (LF) of 24-inch diameter transmission main and 2,500 LF of 18-inch diameter transmission main; complete electrical, instrumentation, controls and telemetry systems; and associated mobilization, site work and appurtenances. The work also includes water connections into existing systems.

**Port of Walla Walla Burbank Business Park Lift Station No. 2- \$937,973.57** **Complete 2022**

The work includes installation of approximately 2,265 feet of 8-, 10- and 12-inch gravity sewer pipe, 175 feet of 6-inch pressure sewer pipe, 13 manholes, one sewer lift station, one water service connection, and site mass grading. Also included will be surface restoration.

**Port of Woodland Centennial Industrial Park - \$2,275,291.50** **Completed 2022**

Port of Woodland Industrial Park - Includes Utilities, dewatering, street improvements and landscaping

**Milwaukie 22<sup>nd</sup> Ave. and River Road - \$1,790,156.25** **Complete 2022**

Install approximately 800 lineal feet of 12-inch Storm Sewer Pipe. Install approximately six (6) Storm Sewer Manholes. Install approximately nine (9) Storm Sewer Inlets. Remove by cold planning approximately 7,900 square yard of existing AC pavement. Install approximately 1,780 tons of Asphalt Concrete Pavement. Construct approximately 4,000 lineal feet of concrete curb. Construct approximately



2,750 square feet of concrete driveway. Construct approximately 13,985 square feet of concrete walk. Install approximately 11,000 lineal feet of pavement markings. Install approximately 225 lineal feet of waterline. Install a pressure reducing assembly and vault on existing waterline. Additional and Incidental Work as called out for by the Specifications & Plans.

**Steigerwald Floodplain Restoration Project- \$15,545,589.50**

**Completed 2022**

The purpose of the Steigerwald Project is threefold: (1) to restore hydrologic connectivity between Gibbons Creek, the Columbia River, and adjacent floodplain habitats within the Steigerwald Lake National Wildlife Refuge; (2) to reduce internal flooding and operations costs; and, (3) to improve recreation opportunities at an urban wildlife refuge visited by as many as 90,000 people per year.

**Water Station 1 Phase. 2 -\$18,912,400.00**

**Completed July 2022**

This Project consist of 2 new 4-million-gallon prestressed post tension concrete reservoirs, a new 1-million-gallon welded steel standpipe, and improved site security and access. Replacement of 2 existing concrete water reservoirs and elevated steel water tower, demo, earthwork, utility relocations, water pipelines, drainage systems, roadway, paved paths, tree removal, landscaping, site lighting, heavy duty security fencing, decorative features and much others.

**Wallula Dodd Concrete Reservoir-\$6,127,918.75**

**Completed 2021**

The work includes the design and construction of a nominal 6.2-million-gallon pre stressed wrapped poured in place concrete reservoir tank and associate, installation of approx. 1,400 LF of 24- and 30-inch diameter water mains, approx. 830 LF of 8-, 12- and 30-inch dia. gravity drain system and associated manholes, ring drain system, fencing and gravel surfacing and misc. work

**SR503 Median Barrier-\$1,788,863.17**

**Completed 2021**

SR503 from MP 4.58 to MP 8.09, by installation type F concrete median barrier, impact attenuator, permanent signing, drainage, channelization within project limits, wetland habitat enhancement through selective clearing.

**Wallula Dodd Water Line Transmission-\$ 4,240,4103.05**

**Completed 2020**

Includes construction of approx. 435'of 12" water line, 15,850' of 18" waterline, 14.095 ft. of 24-inch waterline, and 2,280 ft. of 30-inch water line, 460ft of 36-inch casing, 800 ft. of 18inch utility casing, 6250 cubic yards of excavation, 4,200 cubic yards of embankment compaction, valves and fittings, combination air/vacuum valve assemblies, and manholes. Blow off hydrant and drainage swales, restoration work, concrete splash pads, testing, together with all other work.

**152<sup>nd</sup> Ave Reservoir - \$ 11,356,914.20**

**Completed 2020**

Construction of a partially buried 6.0 Million gallon (MG) Prestressed concrete reservoir, a fully buried, cast in place concrete vault structure and associated electrical control building of concrete masonry unit and wood framed roof construction, design and installation of temporary construction shoring systems as required for construction of the proposed reservoir and valve vault structures; furnish and install buried storm water detention facility, site clearing including tree cutting, and grading, and earthwork at reservoir site and adjacent utility easements, excavation for and backfilling of above components as required for a complete installation, furnish and install approximately 3,000 LF of Class 52 restrained ductile iron water





main, 36 inch and 24 inch diameter sizes, connect the new water mains to existing main lines including transmission and reservoir site connections, abandonment of existing water main and restoration of work site area to original or better conditions, including grading, temporary and permanent paving, erosion control and other measures as required.

**Mill Plain Blvd. 104<sup>th</sup> to Chklov - \$3,642,909.83**

**Completed 2020**

Corridor improvements including pavement widening, roadway surfacing, curbs, sidewalks, storm drainage, signals, striping, signage, water, sewer, landscaping, a new roadway extension, and other work, all in accordance with the attached contract plans, provisions, standard specifications.

## **EXPERIENCE AS PROJECT FOREMAN/SUPERINTENDENT**

**North Shore Sewer Transmission System-\$ 9,665,032.10**

**January 2018**

Improvements for the city of Camas, sewer and water system through installation of approximately 39,000 feet of 6" and 8" diameter HDPE force main pipes, approx. 2,200' of 12" and 18" diameter PVC gravity sewer pipes, two new sewer pumping stations, modifications to a sewer pumping station constructed by others, a remote odor control facility, a 150 ft. long pedestrian bridge, and approx. 10,000 ft. of 12" diameter ductile iron water pipe to serve development of the N. shore Area.

**Voight's Creek Hatchery- \$ 9,683,000**

**Completed 2015**

Construction of a new hatchery included a new intake, fish ladder, rearing ponds, adult ponds, pollution abatement ponds, office building, hatchery building, feed storage building, house moving, piping, cofferdamming, dewatering, demolition, earthwork, asphalt paving, concrete work, mechanical and electrical work, generator pumps, pre-engineered metal buildings.

**McAllister Wellfield-\$4,628,268**

**Completed 2014**

Construction of 3 CMU well houses, equipping 3 wells with vertical turbine well pumps, installation of a gas chlorination system, associated site work, piping and electrical, telemetry and controls.

**Cowlitz County Headquarters Landfill Leachate Transmission System-\$7,347,346**

**Completed 2014**

Construction of approximately 78,000lf of 8in HDPE leachate force main through open-trench and horizontal drilling methods, air release valve stations, pigging stations, leachate pump station, leachate pond modifications, connect to existing sanitary sewer system, pipeline appurtenances and surface restoration.

**Thompson Hill Zone 4 Reservoirs & Booster Pump Station-\$4,668,245**

**Completed 2014**

Project consists of construction of a 3.0 MG prestressed concrete reservoir, an above grade concrete-and-cmu building, inline centrifugal pumps, chlorine generation and injection system, mechanical, HVAC. Site work includes grading, final grading, landscaping & irrigation systems, access road construction, site fencing and utilities including approx. 375lf of 16in DI inlet and outlet pipe, reservoir overflow and drain, booster pump station suction and discharge piping, electrical conduits, and installation of an altitude vault inside a precast vault.



**McNary Lock and Dam Potable Water Distribution System-\$2,167,668**

**Completed 2014**

*The new water distribution system construction work included: Liquid chlorination system; Pipe trench excavation and underground boring for railroad and roadway locations for the new potable water distribution pipelines; Site preparation for a new potable water (concrete reinforced) storage tank with chain link security fencing around it and a rip rap overflow ditch outfall section starting at the end of the water tank drainage pipe; Valves and valve groups subsurface enclosures (concrete manholes); Fire hydrant procurements and placements with protection bollards; Underground fiber optic cable procurement and placement from the new water tank to just outside the Powerhouse; Demolition of some existing valve groups piping during the construction phase to upgrade the water distribution system; and Demolition of the old water tank after de-commissioning of the old water distribution system.*



**Karsten Rotschy**  
General Superintendent

*Karsten joined Rotschy, Inc. in 2009 starting in the field as a laborer and equipment operator. His ability to manage field work quickly led to his promotion to job foreman, field superintendent, and then general superintendent. He is currently responsible for coordinating our labor and equipment resources and managing our field crews to ensure our completed projects exceed the expectations of the people and organizations we work for. In his role as superintendent, Karsten has supervised the construction of many of our largest public works projects. Karsten has been a general superintendent for two years.*

**WORK EXPERIENCE**

**Rotschy, Inc. – Field Laborer, Equipment Operator, Foreman, Superintendent** **2009 – Current**

The majority of Karsten’s work experience at Rotschy, Inc. has been on public works projects. He started working as a laborer on the WSDOT NE 134<sup>th</sup> Street Interchange project at the junction of I-5 and I-205 in Clark County. As a foreman, Karsten supervised field crews on the Clark County NE 119<sup>th</sup> Street improvement project, the WSDOT SR502 widening project, and the City of Vancouver Columbia Way project. He has overseen several jobs as a field superintendent, including, the City of Sandy Portland Water Bureau Intertie, the City of West Linn Bolton Reservoir, the Oregon Military Department Camp Withy comb sanitary sewer project, and the City of Camas North Shore Transmission Main project.

**EXPERIENCE AS SUPERINTENDENT**

**Granite Highlands-~~\$~~Upon Request** **In Progress**

**Steigerwald Floodplain Restoration-~~\$~~15,545,589.50** **In Progress**

The purpose of Steigerwald is threefold: (1) the restore hydrologic connectivity between Gibbons Creek, the Columbia River, and adjacent floodplain habitats within the Steigerwald Lake National Wildlife Refuge; (2) to reduce internal flooding and operation cost; and (3) to improve recreation opportunities at an urban wildlife refuge visited by as many as 90,000 people a year.

**Water Station 1 Phase. 2 -~~\$~~18,912,400.00** **Project Start: May 2019 | Completed July 2022**

Project Contact: City of Vancouver – Steve Lee (360) 487-7750 [steve.lee@cityofvancouver.us](mailto:steve.lee@cityofvancouver.us)  
This Project consist of 2 new 4-million-gallon prestressed post tension concrete reservoirs, a new 1-million-gallon welded steel standpipe, and improved site security and access. Replacement of 2 existing concrete water reservoirs and elevated steel water tower, demo, earthwork, utility relocations, water pipelines, drainage systems, roadway, paved paths, tree removal, landscaping, site lighting, heavy duty security fencing, decorative features and much others.

**Milwaukie 22<sup>nd</sup> Ave and River Road-~~\$~~1,790,156.25** **Completed 2020**

Install approx. 800 lineal ft of 12-in storm sewer pipe, approx. six (12) storm sewer manholes, approx. nine (11) storm sewer inlets. Remove by cold planning approx. 7900 SY of existing AC Pavement. Install approx. 1780 tons asphalt concrete pavement. Construct approx. 4000 lineal ft of concrete curb, approx.2750 SF of concrete driveway, approx. 13985 SF of concrete walk, approx. 11000 lineal ft of



pavement markings, and approx. 225 lineal ft of waterline. Install a pressure reducing assembly and vault on existing waterline.

**Andersen Dairy-\$222,840.00**

**Completed 2020**

**Wiebold Industrial and Commercial Development-\$15,000,000.00**

**Completed 2020**

**152<sup>nd</sup> Ave Reservoir - \$ 11,356,914.20**

**Project Start: March 2018 | Completed: August 2020**

Project Contact: MurraySmith Engineering – Lael Alderman (503) 225-9010 lae.alderman@murraysmith.us  
Construction of a partially buried 6.0 Million gallon (MG) Prestressed concrete reservoir, a fully buried, cast in place concrete vault structure and associated electrical control building of concrete masonry unit and wood framed roof construction, design and installation of temporary construction shoring systems as required for construction of the proposed reservoir and valve vault structures; furnish and install buried storm water detention facility, site clearing including tree cutting, and grading, and earthwork at reservoir site and adjacent utility easements, excavation for and backfilling of above components as required for a complete installation, furnish and install approximately 3,000 LF of Class 52 restrained ductile iron water main, 36 inch and 24 inch diameter sizes, connect the new water mains to existing main lines including transmission and reservoir site connections, abandonment of existing water main and restoration of work site area to original or better conditions, including grading, temporary and permanent paving, erosion control and other measures as required.

**Roosevelt Regional Landfill- \$ 4,163,193.00**

**Completed 2019**

Construction of the project included excavation and subgrade preparation, placement of embankment, soil stockpiling, berm construction, manufacture and placement of drainage aggregate over geosynthetics, HDPE Pipe installation, excavation and backfilling geosynthetics anchor trenches, and potential misc. construction.

**NE 119<sup>th</sup> St East, NE 87<sup>th</sup> Ave to NE 112<sup>th</sup> Ave-\$11,060,454.70**

**Completed 2019**

This project is to widen the roadway two lanes to the standards of a four lane minor arterial which includes, center left turn lanes, sidewalks and bike lanes. Water lines, sewer lines installation and railroad crossing signals.

**City of Camas North Shore Sewer Transmission – \$10,458,241**

**Completed 2018**

Karsten is currently supervising the construction of sewer and water transmission improvements for the city of Camas. Work on this project includes approximately 39,000 feet of six- and eight-inch diameter HDPE force main, approximately 2,200 feet of 12- and 18-inch diameter PVC gravity sewer pipes, two new sewer pump stations, modifications to an existing sewer pump station, a remote odor control facility, one 150-foot long pedestrian bridge, and approximately 10,000 feet of 12-inch diameter ductile iron water pipe. A portion of the shared utility trench was in bedrock, and Rotschy subcontracted the rock excavation to a firm that removed the rock with a trench grinder instead of blasting.

**City of West Linn Bolton Reservoir – \$9,665,032**

**Project Start: Nov. 2015 | Completed: Nov. 2017**

Project Contact: City of West Linn – Erich Lais (503) 722-3434 elais@westlinnoregon.gov

Karsten was just recently the field superintendent on this project that involved the construction of a new 4.0-MG circular pre-stressed concrete reservoir and the demolition and removal of an old 2.5-MG reservoir. Rotschy subcontracted the concrete tank to Marion Construction, Inc. Other work included



mass excavation, grading, subgrade improvements, water and storm utilities, construction of a new access road, and installation of fencing, landscaping, electrical, instrumentation, controls, and telemetry. Improvements were also made to the existing Bolton Pump Station, including: replacement of the roof, relocating one 200-Hp vertical turbine pump, and installation of one 100-Hp vertical turbine pump and associated piping, pump controls, and valves. The water utilities consisted of approximately 3,100 feet of 24-inch potable water main that exceeded 22 feet deep in some places.

***WSDOT I-5 to Battle Ground, Add Lanes, Stage 2 – \$27,544,360***

***November 2017***

Darin is managing this WSDOT-let project which widened SR-502 from two lanes to a four-lane divided highway between Battle Ground and Dollars Corner. Major elements of work included clearing and grubbing, grading, subgrade improvements, installing storm sewer, surfacing, constructing a bridge and three precast reinforced concrete three sided structures, constructing a structural embankment with concrete columns, installing median barrier, guardrail, pavement markings, traffic signals, illuminations, signing, intelligent transportation system, erosion control, traffic control and associated work.

***OMD Camp Withycomb Sanitary Sewer – \$1,601,287***

***Completed 2017***

Karsten supervised the construction of a new sanitary sewer system to replace failing sewer lines servicing the logistical support areas of Camp Withycombe. Old, leaking lines were removed and replaced with new PVC pipe, and existing manholes were removed and replaced with new pre-cast structures.

***Meriwether Estates, Phase 1 – \$Upon Request***

***Completed 2016***

Karsten supervised the construction of a residential subdivision in Woodland, WA.

***Pacific Lumber & Shipping Storm Water Improvements – \$119,189***

***Completed 2015***

Karsten supervised the construction of storm water drainage improvements at this log-handling facility located in Longview, Washington. Work involved the installation of 12- and 24-inch concrete culvert pipe, channel ditch excavation, outfall modifications, and asphalt saw cutting, removal, and replacement.

***City of Sandy Portland Water Bureau Intertie – \$8,568,096***

***Completed 2014***

This project involved the construction of a 1.0-MG partially buried circular prestressed concrete reservoir and two potable water pump stations (1.0-MG and 1.5-MG) as well as 13,190 feet of 24-inch diameter and 13,800 feet of 18-inch diameter transmission mains. Work also included complete electrical, instrumentation, control and telemetry systems and water, sewer, and storm drain connections.

**EXPERIENCE AS FOREMAN**

***City of Vancouver Columbia Way – \$4,190,971***

***Completed 2015***

The project included grading, storm water collection/ treatment/ conveyance, sanitary sewer, water main, waterline and hydrants, HMA paving, cement concrete curb, gutter and sidewalk, 3 signal systems, signal interconnect, illumination, landscaping, irrigation, a joint utility trench, utility vault and conduit installation, pavement markings and associated work.

***Clark County NE 119<sup>th</sup> Street Widening – \$19,369,388***

***Completed 2017***

This project, let by Clark County, widened NE 119th Street from two lanes to five lanes, including a center turning lane, bicycle lanes, and sidewalks. New construction also included intersection



improvements and new traffic signals at NE 72nd Avenue and NE 87th Avenue as well as installation of storm water systems, water and sewer lines, fish-passage culvert, and wetland mitigation. Installation of the utilities was facilitated by a combination of deep-well and well-point dewatering systems.

***WSDOT SR502, I-5 to Battle Ground, Add Lanes – \$27,544,360***

***Completed 2017***

Karsten worked as a foreman on this WSDOT-let project which widened SR-502 from two lanes to a four-lane divided highway between Battle Ground and Dollars Corner. Major elements of work included clearing and grubbing, grading, subgrade improvements, installing storm sewer, surfacing, constructing a bridge and three precast reinforced concrete three sided structures, constructing a structural embankment with concrete columns, installing median barrier, guardrail, pavement markings, traffic signals, illuminations, signing, intelligent transportation system, erosion control, traffic control and associated work.



## Aaron Carroll

Project Superintendent

Aaron started working for Rotschy, Inc. in 2011 as a field laborer and equipment operator. Aaron was recognized for his hard work and outstanding work ethic and became a Superintendent in 2015.

### WORK EXPERIENCE

**Rotschy, Inc. –Labor, Foreman, Superintendent** **2011 – Current**

Aaron is currently managing pipeline construction crews and civil earthwork crews on utility and subdivision development projects. He tracks field productions, procures materials, and coordinates the services of our subcontractor. Aaron also attends regular construction progress meetings and assists the project manager in negotiating changes or valuing engineering on our jobs.

**Wubben Brothers- Mainline Operator** **2000-2011**

**Tapani, Inc.- Mainline Operator** **1998-2000**

**Nutter Corp-Operator, Labor** **1992-1998**

**George Schmidt and Sons- Labor** **1991-1992**

### EXPERIENCE AS SUPERINTENDENT

**Airport Reservoir and Booster Pump Station- \$10,565,626.00** **In Progress**

This job consists of furnishing all labor, materials and equipment necessary for the construction of a 2.0-million-gallon aboveground welded steel reservoir; a 4,500 gallon per minute firm capacity potable water pump station; approximately 5,000 lineal feet (LF) of 24-inch diameter transmission main and 2,500 LF of 18-inch diameter transmission main; complete electrical, instrumentation, controls and telemetry systems; and associated mobilization, site work and appurtenances. The work also includes water connections into existing systems.

**Tyson WW System Improvements -\$1,846,559.45** **In Progress**

This project includes excavation of 2 sewage lagoon cells with double layer liner totaling 4.8 million-gallon, supply and install sewage treatment equipment. Install 2 sewage lift station with approximately 1000 LF of 10" force main. Supply and install precast disinfection building along with a sodium hypochlorite injection system for sewage disinfection. Relocation of an existing irrigation pivot along with the install of 2000 LF of 12" irrigation piping. Complete startup and commissioning of sewage, disinfection and irrigation systems.

**OMD Camp Umatilla WWTF- \$2,764,500.00** **In Progress**

Construction of anew wastewater treatment facility. Scope of work includes clearing, grubbing, excavation, grading, utility installation, HDPE lagoon liner, Building/ pump station/ Misc. Structures construction, mechanical piping, and equipment, fencing and associated site work.

**Legacy Subdivision Phase 3 & 4 – More Information Upon Request** **Completed 2021**

**Patriot Heights- \$1,393,396.00** **Completed 2021**

Subdivision, Street Lighting, Erosion Control, Earthwork



**Tradewinds Phase. 1 – More Information Upon Request**

**Completed 2021**

**Wallula Dodd Water Line Transmission-\$4,240,410.05**

**Completed 2020**

Includes construction of approx. 435' of 12" water line, 15,850' of 18" waterline, 14,095 ft of 24-inch waterline, and 2,280 ft of 30-inch water line, 460ft of 36-inch casing, 800 ft of 18inch utility casing, 6250 cubic yards of excavation, 4,200 cubic yards of embankment compaction, valves and fittings, combination air/vacuum valve assemblies, and manholes. blow off hydrant and drainage swales, restoration work, concrete splash pads, testing, together with all other work.

**Wallula Dodd Concrete Reservoir-\$6,127,918.75**

**Completed 2020**

The work includes the design and construction of a nominal 6.2-million-gallon prestressed wrapped poured in place concrete reservoir tank and associate, installation of approx. 1,400 LF of 24- and 30-inch diameter water mains, approx. 830 LF of 8,12- and 30-inch dia gravity drain system and associated manholes, ring drain system, fencing and gravel surfacing and misc. work

**Port of Walla Walla Burbank Business Park Lift Station No. 2- \$1,013,949.43**

**Complete**

The work includes installation of approx. 2,265 feet of 8-, 10-, and 12-inch gravity sewer pipe, 175 feet of 6-inch pressure sewer pipe, 13 manholes, one sewer lift station, one water service connection, and site mass grading. Also included will be surface restoration.

**AgriNW 96" Pipeline- More Information Upon Request**

**Completed 2020**

**Minnesota Reservoir- \$3,510,610.25**

**Completed 2019**

The construction of a strand wrapped pre-stressed concrete reservoir with a water storage volume of 1.32 million gallons. Site work related improvements included the demolition of two existing reinforced concrete reservoirs, proposed reservoir subgrade preparation, two soil nail retaining walls, and a storm pond. Utility related improvements include the construction of the proposed inlet, outlet, overflow, and drainpipes, electrical, and control work and connections to existing water main and storm piping infrastructure.

**Roosevelt Regional Landfill – \$4,163,193**

**Completed 2018**

In addition to generating the detailed construction schedule for this landfill project, Sven is also helping manage the documentation process and coordination of subcontractors. Work includes excavation and subgrade preparation, placement of embankment, soil stockpiling, berm construction, crushing, screening and placing drainage aggregate over geosynthetics, and installing HDPE pipe.

**Lakeside and Fisher Hill Roads CRP 281 & 314- \$2,210,670.15**

**Completed 2017**

Construction for the Klickitat County Public Works Department provided for the improvements of 2.20 miles of Lakeside Road and 1.27 Miles of Fisher Hill Road by widening, improvements to horizontal and vertical alignments, installing drainage, storm-water detention ponds, surfacing fencing, guardrails, permanent signing and more.

**CID I-84 Carrier Pipe Crossing-\$238,470.00**

**Completed 2017**





Project consisted of removal of 370 feet of existing 72 inch diameter steel pipe with 310 feet of steel pipe installed inside of the existing 78 inch corrugated metal casing pipe and the furnishing and installation of the 370 feet of new owner supplied 72 inch diameter steel pipe with 310 feet of steel piped installed inside the 72 inch corrugated metal casing. Work also included furnishing all labor, materials, tools, equipment, and incidental required to complete the pipeline.

***SR 224/SR225 Benton City Construct Intersection Improvements-\$2,517,477*** ***Completed 2016***  
Improvements of the SR 224/SR 225 intersection by replacing the existing roadway with a roundabout, relocating the existing park and ride lot, retrofitting the existing drainage system, constructing high-mast light standard foundations, and other work.

***Chapel Hill Boulevard Subdivision- More Information Upon Request*** ***Completed 2013***

***Sunnyside Valley Irrigation District Milepost 37.10 Reservoir – \$5,213,650*** ***Completed 2011***  
Project was to build a PVC membrane lined irrigation water storage reservoir with approximately 300 acre-feet of capacity. The design allows for water inflow from the adjacent canal through a motorized slide gate. Additional reinforced concrete structures include a ramo flume, inlet/Waste way structure and a check structure. Work included a significant amount of earthwork, concrete structures, steel and HDPE pipe, PVC lining and electrical work. Use of the existing raw rock included overburden excavation and stockpiling and material screening, crushing, loading, hauling and stockpiling.

***Pasco Sewer Extension-\$241,750*** ***Completed 2011***  
Installed approximately 3600 Lf of 8” PVC sanitary sewer and trench patching.



## ***APPENDIX D***

- ***5.7 – PROJECT SCHEDULE***

## IRZ Ordnance Multi-Use Water Project Preliminary Construction Schedule

<b><u>Preconstruction &amp; General Tasks</u></b>	228 days	4/19/2023 8:00	3/1/2024 17:00
Bid Opening	1 day	4/19/2023 8:00	4/19/2023 17:00
Award	15 days	4/20/2023 8:00	5/10/2023 17:00 2
Owner Procured Materials	175 days	5/11/2023 8:00	1/10/2024 17:00 3
Preconstruction Meeting	1 day	6/15/2023 8:00	6/15/2023 17:00 3FS+25 days
Notice to Proceed	1 day	5/11/2023 8:00	5/11/2023 17:00 3
CAD Files to Contractor	1 day	5/11/2023 8:00	5/11/2023 17:00 3
Submittals	100 days	5/11/2023 8:00	9/27/2023 17:00 3
Contractor Procured Materials	125 days	5/11/2023 8:00	11/1/2023 17:00 3
Coordination / Planning / Scheduling with Owner & Owners Materials Suppliers	125 days	5/11/2023 8:00	11/1/2023 17:00 3
Contractor obtained Permits	75 days	5/11/2023 8:00	8/23/2023 17:00 3
Testing	80 days	11/6/2023 8:00	2/23/2024 17:00
Surveying	100 days	10/16/2023 8:00	3/1/2024 17:00
<b><u>Pump Station Constructon</u></b>	84 days	11/6/2023 8:00	2/29/2024 17:00
Set Underground Steel Manifolds	10 days	11/6/2023 8:00	11/17/2023 17:00
Pump Can Modification	5 days	11/20/2023 8:00	11/24/2023 17:00 15
Underground Piping	5 days	11/27/2023 8:00	12/1/2023 17:00 16
Underground Electrical	5 days	12/4/2023 8:00	12/8/2023 17:00 17
Subgrade & Base Rock Pump Station	5 days	12/11/2023 8:00	12/15/2023 17:00 18
Pour Pump Station Slab	5 days	12/18/2023 8:00	12/22/2023 17:00 19
Owner Furnished & Installed Pumps	10 days	1/29/2024 8:00	2/9/2024 17:00 20FS+25 days
Mechanical Piping incl Air Burst System	10 days	2/12/2024 8:00	2/23/2024 17:00 21
Programming	2 days	2/26/2024 8:00	2/27/2024 17:00 22
Startup and Testing	2 days	2/28/2024 8:00	2/29/2024 17:00 23
Closeout Building Permits; Copies to Owner	1 day	3/1/2024 8:00	3/1/2024 17:00 24
<b><u>Electrical Building Construction</u></b>	64 days	12/4/2023 8:00	2/29/2024 17:00
Underground Electrical	5 days	12/4/2023 8:00	12/8/2023 17:00 17
Prepare Subgrade, Place Base Rock	3 days	12/11/2023 8:00	12/13/2023 17:00 27
Construct Footings and Foundation	10 days	12/14/2023 8:00	12/27/2023 17:00 28
Construct Pre Engineered Metal Building	20 days	12/28/2023 8:00	1/24/2024 17:00 29
Rough In Electrical	11 days	1/25/2024 8:00	2/8/2024 17:00 30
HVAC	5 days	1/25/2024 0:00	1/30/2023 0:00
Final Electrical	10 days	2/9/2024 8:00	2/22/2024 17:00 31
Programming	2 days	2/23/2024 8:00	2/26/2024 17:00 32
Startup and Testing	2 days	2/27/2024 8:00	2/28/2024 17:00 33
Closeout Building Permits; Copies to Owner	1 day	2/29/2024 8:00	2/29/2024 17:00 34
<b><u>Phase 1 Pipeline Construction</u></b>	132 days	8/28/2023 8:00	2/27/2024 17:00
Coordinate Pipeline Construction Access and	5 days	8/28/2023 8:00	9/1/2023 17:00
Coordinate with WEID	5 days	9/4/2023 8:00	9/8/2023 17:00 37
Offload and Stage Pipe Materials	20 days	9/4/2023 8:00	9/29/2023 17:00 37
Highway 730 Bored Crossing; start mid Octok	15 days	10/2/2023 8:00	10/20/2023 17:00 39
Strip & Stockpile Topsoil in Farm Ground Are	5 days	10/23/2023 8:00	10/27/2023 17:00 40
Training on FRP by Pipe Supplier	2 days	10/30/2023 8:00	10/31/2023 17:00 41
Pipeline Construction	70 days	11/1/2023 8:00	2/6/2024 17:00 42

Screening & Crushing	60 days	10/30/2023 8:00	1/19/2024 17:00	41
Replace Topsoil in Farm Ground Areas	5 days	1/22/2024 8:00	1/26/2024 17:00	44
Air Release Vaults & Appurtances	60 days	11/13/2023 8:00	2/2/2024 17:00	41FS+10 days
Testing	10 days	2/7/2024 8:00	2/20/2024 17:00	46,43
Cleanup	5 days	2/21/2024 8:00	2/27/2024 17:00	47
<b><u>2 year Warranty Period</u></b>	520 days	2/21/2024 8:00	2/17/2026 17:00	47
<b><u>Phase 2 Pipeline Construction</u></b>	181 days	9/4/2023 8:00	5/13/2024 17:00	
Coordinate with Land Owners	5 days	9/4/2023 8:00	9/8/2023 17:00	
Offload and Stage Pipe Materials	10 days	10/9/2023 8:00	10/20/2023 17:00	39
Pipeline Construction	60 days	2/7/2024 8:00	4/30/2024 17:00	43
Screening & Crushing	50 days	2/7/2024 8:00	4/16/2024 17:00	43
Air Release Vaults & Appurtances	50 days	2/21/2024 8:00	4/30/2024 17:00	43FS+10 days
Testing	5 days	5/1/2024 8:00	5/7/2024 17:00	55,53
Cleanup	4 days	5/8/2024 8:00	5/13/2024 17:00	56
<b><u>2 Year Warranty Period</u></b>	520 days	5/14/2024 8:00	5/11/2026 17:00	57
<b><u>Asbuilt Plans to Owner for all Phases of Con</u></b>	<b>1 day</b>	<b><u>5/14/2024 8:00</u></b>	<b><u>5/14/2024 17:00</u></b>	<b>57</b>



## ***APPENDIX E***

- **5.8 – COSTS**

**PROPOSAL SHEET**  
ITB-009 General Contractor

Line Item	Project Phase	Category	Task Description	Quantity	Unit of Measurement	Unit Price (USD)	Extended Price (USD)
1	Phase 1	Civil	Mobilization	1	LS	610,500.00	610,500.00
2	Phase 1	Civil	Electrical Building and Pump Station Foundation Excavation and Compaction	1	LS	30,000.00	30,000.00
3	Phase 1	Civil	Pump Station Site Grading	3000	YD	11.50	34,500.00
4	Phase 1	Civil	Pump Station Site Final Grading and 3/4" Gravel	250	YD	109.00	27,250.00
5	Phase 1	Civil	Pump Station Security Fence, Man Gate and Double 12ft Gates	550	LF	90.00	49,500.00
6	Phase 1	Structural	Pump Station Concrete Pad, Pedestals, 4" Drainage System	1	LS	90,000.00	90,000.00
7	Phase 1	Structural	Electrical Building Foundation and Mechanical Pads	60	YD	1,110.00	66,600.00
8	Phase 1	Structural	Pre-Engineered Steel Building (Furnish and Install)	1	LS	190,000.00	190,000.00
9	Phase 1	Electrical	Electrical Building Electrical, provide panelboards and all 120/208 circuits as required. Provide and install LED Lighting (interior and exterior (full perimeter) etc.)	1	LS	25,000.00	25,000.00
10	Phase 1	Mechanical	Electrical Building HVAC	1	LS	125,000.00	125,000.00
11	Phase 1	Electrical	Compressed Air Instrumentation and Electrical	1	LS	15,000.00	15,000.00
12	Phase 1	Mechanical	Airburst Compressor Installation, Piping and Appurtenances	1	LS	24,000.00	24,000.00
13	Phase 1	Mechanical	Air Burst System, Air Receiver Tank and Steel Pipe, Manifold, Valves and Stainless Steel Piping	1	LS	48,000.00	48,000.00
14	Phase 1	Civil	Airburst Pipelines, 6" SDR 9, PE4710, HDPE Pipe and Installation	1	LS	68,000.00	68,000.00
15	Phase 1	Structural	Hydropneumatic Tank Foundation (Strip Footings)	35	YD	1,252.00	43,820.00

16	Phase 1	Mechanical	Hydropneumatic Tank Installation and Furnish and Installing Piping to 48" Manifold	1	LS	37,500.00	37,500.00
17	Phase 1	Electrical	4160V Electrical Gear Installation (gear supplied by Owner) and 4160V Motor Wiring, Conductors and Conduit	1	LS	76,000.00	76,000.00
18	Phase 1	Electrical	Supply and install 480VAC MDP-B and all 480VAC Conduit and Wire.	1	LS	36,500.00	36,500.00
19	Phase 1	Electrical	Pump Station Instrumentation and Electrical (18" Flowmeters, Pressure Transducers, Level Transmitters, Motor Instrumentation etc.)	1	LS	80,000.00	80,000.00
20	Phase 1	Mechanical	Pump Discharge Manifold Installation	1	LS	16,500.00	16,500.00
21	Phase 1	Mechanical	Pump Station Discharge Piping	1	LS	166,000.00	166,000.00
22	Phase 1	Mechanical	Pump Station Pressure Relief Piping	1	LS	44,000.00	44,000.00
23	Phase 1	Mechanical	Pump Station Drain Piping and Existing Intake Manifold Modifications	1	LS	73,500.00	73,500.00
24	Phase 1	Civil	48" Flowmeter and Vault	1	LS	40,000.00	40,000.00
25	Phase 1	Civil	Steel Mainline Installation, 48", Stations - 0+10 to 26+40	2650	LF	115.00	304,750.00
26	Phase 1	Civil	Steel Mainline Bedding/Backfill (Requiring Processing), 48", Stations -0+10 to 26+40	8000	YD	16.00	128,000.00
27	Phase 1	Civil	Mainline Thrust Blocking, Stations -0+10 to 26+40	40	YD	241.00	9,640.00
28	Phase 1	Civil	Shoreline Road Paved Open Cut Crossing	1	LS	17,500.00	17,500.00
29	Phase 1	Civil	HWY 730 Bore, 58", Stations 9+75 to 11+00	1	LS	355,550.00	355,550.00
30	Phase 1	Civil	Remove Existing Concrete Structure on North side of WEID Canal	10	yd	275.00	2,750.00
31	Phase 1	Civil	WEID Canal Crossing Structures	1	LS	188,000.00	188,000.00
32	Phase 1	Civil	WEID Earthwork	230	YD	16.00	3,680.00
33	Phase 1	Civil	Mainline Check Valve Assembly	1	LS	8,300.00	8,300.00

34	Phase 1	Civil	Mainline Check Valve Assembly Vault	1	LS	112,000.00	112,000.00
35	Phase 1	Electrical	65ft Radio Tower #1 and Foundation	1	LS	28,000.00	28,000.00
36	Phase 1	Electrical	Radio Tower #1, Electrical install (County to Provide Transformer within 75ft, Owner to provide Remote Station Cabinet (RSC))	1	LS	35,000.00	35,000.00
37	Phase 1	Civil	Security Fence and Man Gate	60	LF	145.00	8,700.00
38	Phase 1	Civil	Radio Tower# 1/ Check Valve Vault Site Final Grading and 3/4" Gravel	10	YD	181.00	1,810.00
39	Phase 1	Civil	FRP Mainline Installation, 1300mm, Stations 26+40 to 163+46	13706	LF	37.00	507,122.00
40	Phase 1	Civil	FRP Mainline Bedding/Backfill Material (Requiring Processing), 1300mm, Stations 26+40 to 163+46	31000	YD	10.75	333,250.00
41	Phase 1	Civil	FRP Mainline Top Soil Stripping, 1300mm, Stations 26+40 to 163+46	1	LS	32,500.00	32,500.00
42	Phase 1	Civil	Install 64" Steel Casing, 1300mm Carrier, End Seals, and Casing Spacers, Under Williams Gas Lines (Open Cut) (68+40 to 69+40)	100	LF	584.00	58,400.00
43	Phase 1	Civil	Mainline Airvent/Drain Assemblies and Vaults, 1300mm, Stations 26+40 to 163+46	7	EA	27,250.00	190,750.00
44	Phase 1	Civil	Mainline Thrust Blocks 1300mm, Stations 26+40 to 163+55	46	YD	240.00	11,040.00
45	Phase 1	Civil	COU Delivery Point, 48" Valves, Airvent and Vault Installation Station 163+55	1	LS	33,000.00	33,000.00
46	Phase 1	Electrical	COU Delivery Point, Electrical install (County to Provide Transformer within 75ft, Owner to provide Remote Station Cabinet (RSC))	1	LS	37,000.00	37,000.00
47	Phase 1	Electrical	COU Delivery Point Instrumentation and Electrical (20" Flowmeter and Pressure Transducers)	1	LS	3,100.00	3,100.00
48	Phase 1	Civil	COU Delivery Point, Flowmeter and Vault	1	LS	43,000.00	43,000.00
49	Phase 1	Civil	COU Delivery Point, Airvent Assembly and Vault	1	LS	28,000.00	28,000.00
50	Phase 1	Electrical	65ft Radio Tower #2 and Foundation	1	LS	28,000.00	28,000.00



51	Phase 1	Civil	COU Delivery Point Site Final Grading and 3/4" Gravel	100	YD	107.00	10,700.00
52	Phase 1	Civil	COU Delivery Point Security Fence, Man Gate and Double 12ft Gates	350	LF	99.00	34,650.00
53	Phase 1	Civil	Phase 1 Pressure Testing Punch Lists, Cleanup and Alignment/Road/Laydown Yard Rehabilitation	1	LS	26,000.00	26,000.00
54	Phase 1	Civil		1	LS	25,000.00	25,000.00
55	Phase 1	Civil	Phase 1 Rock Excavation Rate	1	yd	269.00	269.00
56	Phase 1	Civil	Phase 1 Contingency Allowance	1	LS	\$250,000.00	\$250,000.00
<b>Phase 1 Subtotal</b>							
57	Phase 2	Civil	FRP Mainline Installation, 1300mm, Stations 163+64 to 196+16	3252	LF	32.00	104,064.00
58	Phase 2	Civil	FRP Mainline Bedding/Backfill (Requiring Processing), 1300mm, Stations 163+64 to 196+16	8000	YD	10.75	86,000.00
59	Phase 2	Civil	Mainline Airvent Assemblies and Vaults, 1300mm, Stations 163+64 to 196+16	1	EA	27,500.00	27,500.00
60	Phase 2	Civil	FRP Mainline Installation, 1100mm, Stations 196+28 to 336+00	13972	LF	35.00	489,020.00
61	Phase 2	Civil	FRP Mainline Bedding/Backfill (Requiring Processing), 1100mm, Stations 196+28 to 336+00	31000	YD	10.75	333,250.00
62	Phase 2	Civil	Mainline Airvent/Drain Assemblies and Vaults, 1100mm, Stations 196+28 to 336+00	6	EA	27,500.00	165,000.00
63	Phase 2	Civil	Mainline Thrust Blocks, 1100mm, Stations 163+55 to 336+00	50	YD	240.00	12,000.00
64	Phase 2	Civil	1300mm x 1100mm Tee Station 196+22	1	LS	3,300.00	3,300.00
65	Phase 2	Civil	Ordnance Lateral Tee's, Airvents, 42" Valves and Vaults Station 270+61	1	LS	53,000.00	53,000.00
66	Phase 2	Civil	Depot Paved Road Open Cut Crossings	1	LS	11,000.00	11,000.00
67	Phase 2	Civil	Recharge Basin Delivery Point Manifold, Flowmeter, Airvent, Vaults and 42" Valve Installation Station 336+00	1	LS	53,000.00	53,000.00

68	Phase 2	Electrical	65ft Radio Tower #3 and Foundation Recharge Basin Delivery Point, Electrical install (County to Provide Transformer within 75ft, Owner to provide Remote Station Cabinet (RSC))	1	LS	29,000.00	29,000.00
69	Phase 2	Electrical	Recharge Basin Delivery Point Instrumentation and Electrical (42" Flowmeter and Pressure Transducers)	1	LS	38,000.00	38,000.00
70	Phase 2	Electrical	Radio Tower# 3/ Recharge Basin Delivery Point Site Final Grading and 3/4" Gravel	1	LS	3,100.00	3,100.00
71	Phase 2	Civil	Punch Lists, Cleanup and Alignment/Road/Laydown Yard Rehabilitation	25	YD	152.00	3,800.00
72	Phase 2	Civil	Phase 2 Rock Excavation Rate	1	LS	25,000.00	25,000.00
73	Phase 2	Civil	Contingency Allowance	1	YD	269.00	269.00
74	Phase 2	Civil		1	LS	\$125,000.00	\$125,000.00
						<b>Phase 2 subtotal</b>	<b>1,561,303.00</b>
						<b>Total Amount</b>	<b>6,433,934.00</b>

X \_\_\_\_\_ (Please Check or Initial) Proposer will comply with the provisions of ORS 279C.800 -.870, including the payment of the applicable prevailing rate of wage.

Proposer certifies this proposal is valid for 60 \_\_\_\_\_ calendar days.

Proposer Rotschy, LLC dba Rotschy, Inc.

Address 7408 NE 113th Circle, Vancouver, WA 98662

By (Print) Drew Rotschy, Vice President

By (Signed) 



## ***APPENDIX F***

- ***5.9 – FINANCIAL INFORMATION***

**THE  
CINCINNATI CASUALTY COMPANY**  
CINCINNATI, OHIO

**Bid Bond  
PUBLIC CONTRACTS**

**KNOW ALL MEN BY THESE PRESENTS**, that we Rotschy LLC, 7408 NE 113th Circle, Vancouver, WA 98662

as Principal, hereinafter called the Principal, and THE CINCINNATI CASUALTY COMPANY, 6200 South Gilmore Road, Fairfield, Ohio 45014-5141, a corporation duly organized under the laws of the State of Ohio, as Surety, hereinafter called the Surety, are held and firmly bound unto

Umatilla County, 216 S.E. 4th Street, Pendleton, OR 97801

as Obligees, hereinafter called the Obligees, in the sum of Five percent of total amount bid

Dollars (\$ 5% of total amount bid ),

for the payment of which sum well and truly to be made, the said Principal and the said Surety, bind ourselves, our heirs, executors, administrators, successors and assigns, jointly and severally, firmly by these presents.

WHEREAS, the Principal has submitted a bid for

Ordinance Multi-Use Water Project

NOW, THEREFORE, if the Obligees shall accept the bid of the Principal within the period specified therein for acceptance (60 days if no period is specified) and the Principal shall enter into a Contract with the said Obligees in accordance with the terms of said bid and give bond for the faithful performance thereof within the period specified (30 days if no period is specified); or if the Principal shall, in the case of failure to do so, indemnify the Obligees against any loss the Obligees may suffer directly arising by reason of such failure, not to exceed the penalty of this bond, then this obligation shall be null and void; otherwise to remain in full force and effect.

Signed and sealed this 13th

day of April, 2023

Rotschy LLC

(Principal)

(Seal)

By:



Drew Rotschy, Vice President

(Title)

**THE CINCINNATI CASUALTY COMPANY**

(Seal)

By:



Jeanette Simmons

Attorney-in-Fact

THE CINCINNATI INSURANCE COMPANY  
THE CINCINNATI CASUALTY COMPANY

Fairfield, Ohio

POWER OF ATTORNEY

KNOW ALL MEN BY THESE PRESENTS: That THE CINCINNATI INSURANCE COMPANY and THE CINCINNATI CASUALTY COMPANY, corporations organized under the laws of the State of Ohio, and having their principal offices in the City of Fairfield, Ohio (herein collectively called the "Companies"), do hereby constitute and appoint

of their true and legal Attorney(s)-in-Fact, each in their separate capacity if more than one is named above, to sign, execute, seal and deliver on behalf of the Companies as Surety, any and all bonds, policies, undertakings or other like instruments, as follows:

This appointment is made under and by authority of the following resolutions adopted by the Boards of Directors of The Cincinnati Insurance Company and The Cincinnati Casualty Company, which resolutions are now in full force and effect, reading as follows:

RESOLVED, that the President or any Senior Vice President be hereby authorized, and empowered to appoint Attorneys-in-Fact of the Company to execute any and all bonds, policies, undertakings, or other like instruments on behalf of the Corporation, and may authorize any officer or any such Attorney-in-Fact to affix the corporate seal; and may with or without cause modify or revoke any such appointment or authority. Any such writings so executed by such Attorneys-in-Fact shall be binding upon the Company as if they had been duly executed and acknowledged by the regularly elected officers of the Company.

RESOLVED, that the signature of the President or any Senior Vice President and the seal of the Company may be affixed by facsimile on any power of attorney granted, and the signature of the Secretary or Assistant Vice-President and the Seal of the Company may be affixed by facsimile to any certificate of any such power and any such power of certificate bearing such facsimile signature and seal shall be valid and binding on the Company. Any such power so executed and sealed and certified by certificate so executed and sealed shall, with respect to any bond or undertaking to which it is attached, continue to be valid and binding on the Company.

IN WITNESS WHEREOF, the Companies have caused these presents to be sealed with their corporate seals, duly attested by their President or any Senior Vice President this 16th day of March, 2021.



STATE OF OHIO )SS:  
COUNTY OF BUTLER )

THE CINCINNATI INSURANCE COMPANY  
THE CINCINNATI CASUALTY COMPANY

*Stephen A. Justice*

On this 16th day of March, 2021 before me came the above-named President or Senior Vice President of The Cincinnati Insurance Company and The Cincinnati Casualty Company, to me personally known to be the officer described herein, and acknowledged that the seals affixed to the preceding instrument are the corporate seals of said Companies and the corporate seals and the signature of the officer were duly affixed and subscribed to said instrument by the authority and direction of said corporations.



*Keith Collett*

Keith Collett, Attorney at Law  
Notary Public – State of Ohio

My commission has no expiration date.  
Section 147.03 O.R.C.

I, the undersigned Secretary or Assistant Vice-President of The Cincinnati Insurance Company and The Cincinnati Casualty Company, hereby certify that the above is the Original Power of Attorney issued by said Companies, and do hereby further certify that the said Power of Attorney is still in full force and effect.

Given under my hand and seal of said Companies at Fairfield, Ohio, this \_\_\_\_\_ day of \_\_\_\_\_,



*Ed H.*



## ***APPENDIX G***

- ***5.9 – ADDITIONAL INFORMATION***



## ROTSCHY SAFETY HIGHLIGHTS

- All employees are provided medical, dental, and vision insurance as well as PTO and 401K
- All new employees are given orientation and safety training
- Rotschy provides training for all tasks our employees perform
- Weekly safety meetings are specific to each of our projects
- Our safety manager performs regular site visits and audits
- We contract with a third-party to provide random job-site inspections
- All employees are subject to random drug testing
- We provide Injury recovery assistance including kept-on-salary until able to return to work
- Injured workers are provided light-duty tasks and aided with paperwork as needed

## Safe, Healthy Work Environments

Rotschy's corporate safety program is designed to inspire an individual commitment to safety and accident prevention at all levels within our organization. Safety is equally important to our company's success as the quality of our work and productivity of our crews. Fostering safety awareness reduces accidents which result in job disruptions, lost productivity, and job delays. No task is of such importance that it cannot be completed safely.

Rotschy's provides our employees, subcontractors, and other parties involved in our projects with a safe and healthy work environment. Our employees are provided with reliable equipment, established safe work methods and practices, and employee training, all critical elements for safe and efficient performance of work. Employees are given safety training at orientation for accident prevention, drug and alcohol abuse, CPR/First Aid, hazard assessment and communication, occupational health, trench safety, competent person, forklift and equipment operations, and fleet and driver awareness. Job-specific training provided as needed includes fall protection, lock-out/tag-out, confined space entry, crane and rigging operations, and silica dust management.

Our site-specific safety plan for the Ordnance Multi-Use Water project will address the safety elements summarized above, as these will all likely be applicable to the work performed on the job. The plan will include a pre-construction meeting agenda, job-specific safety orientations, job hazard analyses, work permit requirements, and approved task-specific procedures confined space ingress/egress and rescue, fall hazard protection, etc. Site visits and audits will be routinely performed by our Safety Manager or other designated individuals to identify safety concerns and enforce compliance with our corporate safety program.

## WORKER'S COMPENSATION EXPERIENCE MODIFICATION (EMR)

Rotschy's current Workers' Compensation Experience Modification Ratio (EMR) is 0.5615. Our EMR for the three prior years is summarized below. Incidence frequency rates are also summarized for various incident categories.

YEAR	HOURS WORKED	EMR	INCIDENTS	INCIDENCE RATE
2020	938,309	0.4315	7	1.49
2021	880,395	0.5305	10	2.27
2022	905,547	0.6553	12	2.65
2023		0.5615		



## EQUAL EMPLOYMENT OPPORTUNITIES

Rotschy recognizes its strength and growth in its employees. It is our policy to provide equal employment opportunities to all qualified persons without regard to race, religion, color, sex, national origin, mental or physical disability, or veteran's status in accordance with applicable law.

Employment decisions are based on an individual's qualifications and ability to contribute to the success of our company. Our company currently employs 96 minority, women, and veteran individuals, which is twenty one percent of our total staff.

Rotschy is not a minority contractor. However, we recognize our success depends also upon the success of our subcontractors. We strive to contact and solicit bids from all qualified parties, including minority companies. Minority companies we have worked with speak highly of their experience with Rotschy.

CATEGORY	NUMBER OF INCIDENTS			INCIDENCE RATE		
	2020	2021	2022	2020	2021	2022
Ankle	0	0	4	0	0	0.88
Back	4	9	3	0.85	2.04	0.66
Eye	2	0	2	0.43	0	0.44
Finger	1	2	2	0.21	0.45	0.44
Foot	0	0	1	0	0	0.22
Hand	2	1	1	0.21	0.23	0.22
Knee	0	2	3	0	0.45	0.66
Neck	1	4	2	0.21	0.45	0.88
Ribs	0	1	0	0	0.23	0
Shoulder	0	1	5	0	0.23	1.10
Thigh	0	0	1	0	0	0.22
Wrist	1	1	1	0.21	0.23	0.22

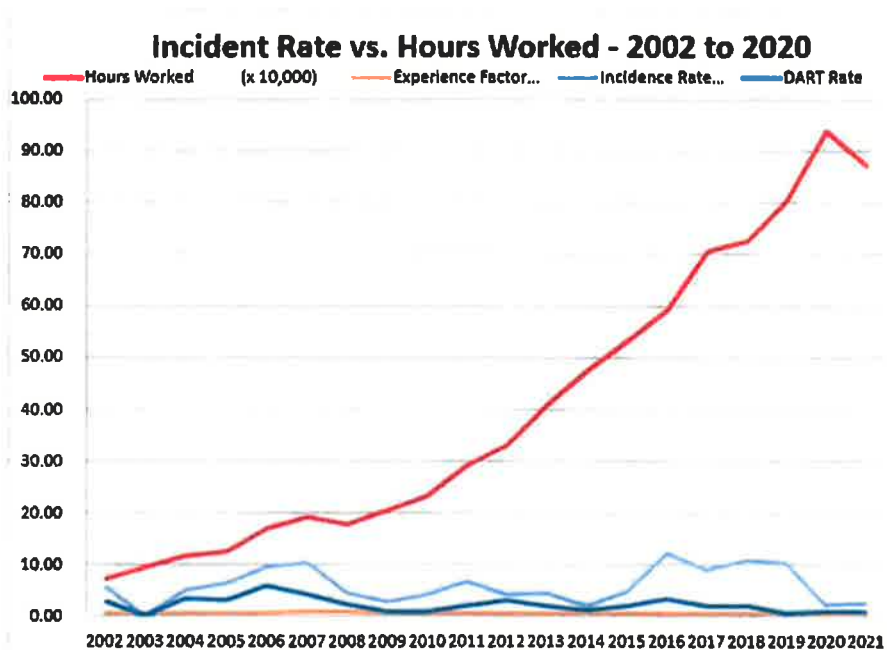

## Demographics of Rotschy's Minority Employees

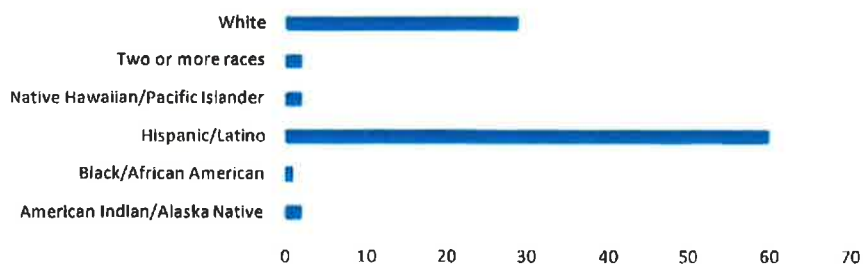



SUBMISSION OF PROPOSAL

# ORDNANCE MULTI-USE WATER PROJECT

SUBMITTED TO: UMATILLA COUNTY

SUBMITTED BY: TAPANI INC

April 19, 2023



# TABLE OF CONTENTS

<b>TAB 5.1</b> Letter of Transmittal.....	NIPC
<b>TAB 5.2</b> Project Understanding.....	1
<b>TAB 5.3</b> Minimum Qualifications.....	3
<b>TAB 5.4</b> General Qualifications (Company Experience & Personnel Experience).....	6
<b>TAB 5.5</b> Project Approach.....	17
<b>TAB 5.6</b> Warranty Repair Approach.....	29
<b>TAB 5.7</b> Project Schedule.....	31
<b>TAB 5.8</b> Costs.....	NIPC
<b>TAB 5.9</b> Financial Information.....	34
<b>TAB 5.10</b> Additional Information.....	35
<b>TAB 5.11</b> Subcontractors/Supplier Solicitation and Utilization.....	39

April 19th, 2023

Umatilla County  
Attn. Board of Commissioners  
216 S.E. 4th Street  
Pendleton, Oregon 97801

Dear Umatilla County Board of Commissioners,

Tapani Inc. is pleased to present our proposal for the Ordnance Multi-Use Water Project. Our experiences in working with IRZ Consulting on the Hillside and Ice Harbor irrigation projects and Umatilla County on the SE Airport Road & S Ott. Rd Improvements project have been positive, successful, and collaborative. If selected as the successful proposer on this project, we look forward to the opportunity to continue these experiences.

As part of our commitment to Umatilla County, Tapani Inc. brings our core values of Strong Teams, Successful Projects. We are committed to providing professional, competent, passionate, trustworthy and unified teams to deliver a project that exhibits excellence in safety, quality, and strategy.

Tapani Inc. uses a partnership approach to construction management, utilizes the newest technology, maximizes our in-house resources to the project's advantage, hires only the most reputable subcontractors, excels in meeting deadlines, and has a positive record of successfully putting local project stakeholders first.

By providing this signed letter of interest, Tapani acknowledges:

- We have received and reviewed all RFP Documents and Supplemental Documentation listed in the RFP, including Addendum 01.
- Proposal is valid for (60) calendar days from the proposal due date.
- Tapani is a resident bidder of Oregon as defined by ORS 279A.120.
- Tapani will comply with all provisions of the applicable prevailing wage rate and law, including Oregon state prevailing wage rates and the posting of a public works bond pursuant to ORS 379C.836.
- Tapani will file a performance bond and payment bond, as required by ORS 279C.380, through Umatilla County (payee) no later than 10 days after the contract is awarded.

Please contact Blaine Bellikka, Regional Manager, with any questions you may have. 2213 Henderson Loop, Richland, WA 99354 | [BlaineB@tapani.com](mailto:BlaineB@tapani.com) | 509-530-8065

We appreciate the opportunity to propose on this project and look forward to answering any questions you may have.

Sincerely,



Tod Tapani  
Vice President of Operations

**BATTLE GROUND (HQ)**

1705 Southeast 9th Ave  
Battle Ground, WA 98604  
360-687-1148  
[info@tapani.com](mailto:info@tapani.com)

**TRI-CITIES**

2213 Henderson Loop  
Richland, WA 99354  
509-590-1184  
[info@tapani.com](mailto:info@tapani.com)

**SHERWOOD**

11175 SW Elligsen Way  
Sherwood, OR 97140  
503-883-3169  
[info@tapani.com](mailto:info@tapani.com)

**Umatilla County  
Ordinance Multi-Use Water Project  
General Contractor ITB-009  
Addendum #1 Acknowledgment Form**

**Prepared by IRZ Consulting, LLC  
4/12/2023**

Instructions: Please acknowledge receipt of Addendum #1 issued with this bid package by completing this addendum acknowledgment form. Failure to acknowledge addenda may result in bid disqualification.

I understand that any verbal representation made or assumed to be made during any oral discussion held between Contractor and Owner or Owner's representatives is not binding. Only the information issued in writing and added to the bid package by an official addendum is binding.

Company: Tapani, Inc.

Authorized Signature:  Kevin Tapani, Vice President

Date: 4/12/2023

**NOTE:** This addendum acknowledgement shall be submitted with the bid.





**Travelers Casualty and Surety Company of America  
Travelers Casualty and Surety Company  
St. Paul Fire and Marine Insurance Company**

**POWER OF ATTORNEY**

**KNOW ALL MEN BY THESE PRESENTS:** That Travelers Casualty and Surety Company of America, Travelers Casualty and Surety Company, and St. Paul Fire and Marine Insurance Company are corporations duly organized under the laws of the State of Connecticut (herein collectively called the "Companies"), and that the Companies do hereby make, constitute and appoint **Gloria Bruning** of **PORTLAND**, **Oregon**, their true and lawful Attorney(s)-in-Fact to sign, execute, seal and acknowledge any and all bonds, recognizances, conditional undertakings and other writings obligatory in the nature thereof on behalf of the Companies in their business of guaranteeing the fidelity of persons, guaranteeing the performance of contracts and executing or guaranteeing bonds and undertakings required or permitted in any actions or proceedings allowed by law.

**IN WITNESS WHEREOF**, the Companies have caused this instrument to be signed, and their corporate seals to be hereto affixed, this **21st** day of **April**, **2021**.



State of Connecticut

City of Hartford ss.

By:   
Robert L. Raney, Senior Vice President

On this the **21st** day of **April**, **2021**, before me personally appeared **Robert L. Raney**, who acknowledged himself to be the Senior Vice President of each of the Companies, and that he, as such, being authorized so to do, executed the foregoing instrument for the purposes therein contained by signing on behalf of said Companies by himself as a duly authorized officer.

**IN WITNESS WHEREOF**, I hereunto set my hand and official seal.

My Commission expires the **30th** day of **June**, **2026**

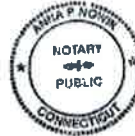

Anna P. Nowik, Notary Public

This Power of Attorney is granted under and by the authority of the following resolutions adopted by the Boards of Directors of each of the Companies, which resolutions are now in full force and effect, reading as follows:

**RESOLVED**, that the Chairman, the President, any Vice Chairman, any Executive Vice President, any Senior Vice President, any Vice President, any Second Vice President, the Treasurer, any Assistant Treasurer, the Corporate Secretary or any Assistant Secretary may appoint Attorneys-in-Fact and Agents to act for and on behalf of the Company and may give such appointee such authority as his or her certificate of authority may prescribe to sign with the Company's name and seal with the Company's seal bonds, recognizances, contracts of indemnity, and other writings obligatory in the nature of a bond, recognizance, or conditional undertaking, and any of said officers or the Board of Directors at any time may remove any such appointee and revoke the power given him or her; and it is

**FURTHER RESOLVED**, that the Chairman, the President, any Vice Chairman, any Executive Vice President, any Senior Vice President or any Vice President may delegate all or any part of the foregoing authority to one or more officers or employees of this Company, provided that each such delegation is in writing and a copy thereof is filed in the office of the Secretary; and it is

**FURTHER RESOLVED**, that any bond, recognizance, contract of indemnity, or writing obligatory in the nature of a bond, recognizance, or conditional undertaking shall be valid and binding upon the Company when (a) signed by the President, any Vice Chairman, any Executive Vice President, any Senior Vice President or any Vice President, any Second Vice President, the Treasurer, any Assistant Treasurer, the Corporate Secretary or any Assistant Secretary and duly attested and sealed with the Company's seal by a Secretary or Assistant Secretary; or (b) duly executed (under seal, if required) by one or more Attorneys-in-Fact and Agents pursuant to the power prescribed in his or her certificate or their certificates of authority or by one or more Company officers pursuant to a written delegation of authority; and it is

**FURTHER RESOLVED**, that the signature of each of the following officers: President, any Executive Vice President, any Senior Vice President, any Vice President, any Assistant Vice President, any Secretary, any Assistant Secretary, and the seal of the Company may be affixed by facsimile to any Power of Attorney or to any certificate relating thereto appointing Resident Vice Presidents, Resident Assistant Secretaries or Attorneys-in-Fact for purposes only of executing and attesting bonds and undertakings and other writings obligatory in the nature thereof, and any such Power of Attorney or certificate bearing such facsimile signature or facsimile seal shall be valid and binding upon the Company and any such power so executed and certified by such facsimile signature and facsimile seal shall be valid and binding on the Company in the future with respect to any bond or understanding to which it is attached.

I, **Kevin E. Hughes**, the undersigned, Assistant Secretary of each of the Companies, do hereby certify that the above and foregoing is a true and correct copy of the Power of Attorney executed by said Companies, which remains in full force and effect.

Dated this 19<sup>th</sup> day of April, 2023



Kevin E. Hughes, Assistant Secretary

**To verify the authenticity of this Power of Attorney, please call us at 1-800-421-3880.**

**Please refer to the above-named Attorney(s)-in-Fact and the details of the bond to which this Power of Attorney is attached.**

SUBMISSION OF PROPOSAL

# ORDNANCE MULTI-USE WATER PROJECT

SUBMITTED TO: UMATILLA COUNTY

SUBMITTED BY: TAPANI INC

April 19, 2023



# TABLE OF CONTENTS

<b>TAB 5.1</b> Letter of Transmittal.....	NIPC
<b>TAB 5.2</b> Project Understanding.....	1
<b>TAB 5.3</b> Minimum Qualifications.....	3
<b>TAB 5.4</b> General Qualifications (Company Experience & Personnel Experience).....	6
<b>TAB 5.5</b> Project Approach.....	17
<b>TAB 5.6</b> Warranty Repair Approach.....	29
<b>TAB 5.7</b> Project Schedule.....	31
<b>TAB 5.8</b> Costs.....	NIPC
<b>TAB 5.9</b> Financial Information.....	34
<b>TAB 5.10</b> Additional Information.....	35
<b>TAB 5.11</b> Subcontractors/Supplier Solicitation and Utilization.....	39



April 19th, 2023

Umatilla County  
Attn. Board of Commissioners  
216 S.E. 4th Street  
Pendleton, Oregon 97801

Dear Umatilla County Board of Commissioners,

Tapani Inc. is pleased to present our proposal for the Ordnance Multi-Use Water Project. Our experiences in working with IRZ Consulting on the Hillside and Ice Harbor irrigation projects and Umatilla County on the SE Airport Road & S Ott. Rd Improvements project have been positive, successful, and collaborative. If selected as the successful proposer on this project, we look forward to the opportunity to continue these experiences.

As part of our commitment to Umatilla County, Tapani Inc. brings our core values of Strong Teams, Successful Projects. We are committed to providing professional, competent, passionate, trustworthy and unified teams to deliver a project that exhibits excellence in safety, quality, and strategy.

Tapani Inc. uses a partnership approach to construction management, utilizes the newest technology, maximizes our in-house resources to the project's advantage, hires only the most reputable subcontractors, excels in meeting deadlines, and has a positive record of successfully putting local project stakeholders first.

By providing this signed letter of interest, Tapani acknowledges:

- We have received and reviewed all RFP Documents and Supplemental Documentation listed in the RFP, including Addendum 01.
- Proposal is valid for (60) calendar days from the proposal due date.
- Tapani is a resident bidder of Oregon as defined by ORS 279A.120.
- Tapani will comply with all provisions of the applicable prevailing wage rate and law, including Oregon state prevailing wage rates and the posting of a public works bond pursuant to ORS 379C.836.
- Tapani will file a performance bond and payment bond, as required by ORS 279C.380, through Umatilla County (payee) no later than 10 days after the contract is awarded.

Please contact Blaine Bellikka, Regional Manager, with any questions you may have. 2213 Henderson Loop, Richland, WA 99354 | [BlaineB@tapani.com](mailto:BlaineB@tapani.com) | 509-530-8065

We appreciate the opportunity to propose on this project and look forward to answering any questions you may have.

Sincerely,



Tod Tapani  
Vice President of Operations

**BATTLE GROUND (HQ)**

1705 Southeast 9th Ave  
Battle Ground, WA 98604  
360-687-1148  
[info@tapani.com](mailto:info@tapani.com)

**TRI-CITIES**

2213 Henderson Loop  
Richland, WA 99354  
509-590-1184  
[info@tapani.com](mailto:info@tapani.com)

**SHERWOOD**

11175 SW Elligsen Way  
Sherwood, OR 97140  
503-883-3169  
[info@tapani.com](mailto:info@tapani.com)

**Umatilla County  
Ordinance Multi-Use Water Project  
General Contractor ITB-009  
Addendum #1 Acknowledgment Form**

**Prepared by IRZ Consulting, LLC  
4/12/2023**

Instructions: Please acknowledge receipt of Addendum #1 issued with this bid package by completing this addendum acknowledgment form. Failure to acknowledge addenda may result in bid disqualification.

I understand that any verbal representation made or assumed to be made during any oral discussion held between Contractor and Owner or Owner's representatives is not binding. Only the information issued in writing and added to the bid package by an official addendum is binding.

Company: Tapani, Inc.

Authorized Signature:  Kevin Tapani, Vice President

Date: 4/12/2023

**NOTE:** This addendum acknowledgement shall be submitted with the bid.





**Travelers Casualty and Surety Company of America  
Travelers Casualty and Surety Company  
St. Paul Fire and Marine Insurance Company**

**POWER OF ATTORNEY**

**KNOW ALL MEN BY THESE PRESENTS:** That Travelers Casualty and Surety Company of America, Travelers Casualty and Surety Company, and St. Paul Fire and Marine Insurance Company are corporations duly organized under the laws of the State of Connecticut (herein collectively called the "Companies"), and that the Companies do hereby make, constitute and appoint **Gloria Bruning** of **PORTLAND, Oregon**, their true and lawful Attorney(s)-in-Fact to sign, execute, seal and acknowledge any and all bonds, recognizances, conditional undertakings and other writings obligatory in the nature thereof on behalf of the Companies in their business of guaranteeing the fidelity of persons, guaranteeing the performance of contracts and executing or guaranteeing bonds and undertakings required or permitted in any actions or proceedings allowed by law.

**IN WITNESS WHEREOF**, the Companies have caused this instrument to be signed, and their corporate seals to be hereto affixed, this **21st** day of **April, 2021**.



State of Connecticut

City of Hartford ss.

By:   
Robert L. Raney, Senior Vice President

On this the **21st** day of **April, 2021**, before me personally appeared **Robert L. Raney**, who acknowledged himself to be the Senior Vice President of each of the Companies, and that he, as such, being authorized so to do, executed the foregoing instrument for the purposes therein contained by signing on behalf of said Companies by himself as a duly authorized officer.

**IN WITNESS WHEREOF**, I hereunto set my hand and official seal.

My Commission expires the **30th** day of **June, 2026**

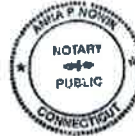

Anna P. Nowik, Notary Public

This Power of Attorney is granted under and by the authority of the following resolutions adopted by the Boards of Directors of each of the Companies, which resolutions are now in full force and effect, reading as follows:

**RESOLVED**, that the Chairman, the President, any Vice Chairman, any Executive Vice President, any Senior Vice President, any Vice President, any Second Vice President, the Treasurer, any Assistant Treasurer, the Corporate Secretary or any Assistant Secretary may appoint Attorneys-in-Fact and Agents to act for and on behalf of the Company and may give such appointee such authority as his or her certificate of authority may prescribe to sign with the Company's name and seal with the Company's seal bonds, recognizances, contracts of indemnity, and other writings obligatory in the nature of a bond, recognizance, or conditional undertaking, and any of said officers or the Board of Directors at any time may remove any such appointee and revoke the power given him or her; and it is

**FURTHER RESOLVED**, that the Chairman, the President, any Vice Chairman, any Executive Vice President, any Senior Vice President or any Vice President may delegate all or any part of the foregoing authority to one or more officers or employees of this Company, provided that each such delegation is in writing and a copy thereof is filed in the office of the Secretary; and it is

**FURTHER RESOLVED**, that any bond, recognizance, contract of indemnity, or writing obligatory in the nature of a bond, recognizance, or conditional undertaking shall be valid and binding upon the Company when (a) signed by the President, any Vice Chairman, any Executive Vice President, any Senior Vice President or any Vice President, any Second Vice President, the Treasurer, any Assistant Treasurer, the Corporate Secretary or any Assistant Secretary and duly attested and sealed with the Company's seal by a Secretary or Assistant Secretary; or (b) duly executed (under seal, if required) by one or more Attorneys-in-Fact and Agents pursuant to the power prescribed in his or her certificate or their certificates of authority or by one or more Company officers pursuant to a written delegation of authority; and it is

**FURTHER RESOLVED**, that the signature of each of the following officers: President, any Executive Vice President, any Senior Vice President, any Vice President, any Assistant Vice President, any Secretary, any Assistant Secretary, and the seal of the Company may be affixed by facsimile to any Power of Attorney or to any certificate relating thereto appointing Resident Vice Presidents, Resident Assistant Secretaries or Attorneys-in-Fact for purposes only of executing and attesting bonds and undertakings and other writings obligatory in the nature thereof, and any such Power of Attorney or certificate bearing such facsimile signature or facsimile seal shall be valid and binding upon the Company and any such power so executed and certified by such facsimile signature and facsimile seal shall be valid and binding on the Company in the future with respect to any bond or understanding to which it is attached.

I, **Kevin E. Hughes**, the undersigned, Assistant Secretary of each of the Companies, do hereby certify that the above and foregoing is a true and correct copy of the Power of Attorney executed by said Companies, which remains in full force and effect.

Dated this 19<sup>th</sup> day of April, 2023



Kevin E. Hughes, Assistant Secretary

**To verify the authenticity of this Power of Attorney, please call us at 1-800-421-3880.**

**Please refer to the above-named Attorney(s)-in-Fact and the details of the bond to which this Power of Attorney is attached.**

equipment and components staged at the pump station site, we will provide the security measures necessary to prevent theft or damage: security fencing, strategic placement of machines and equipment, security cameras, etc.

**SITE SAFETY:** The Jack and Bore operation, Williams Gas Line crossing, BPA power lines crossing, open trench through county roads, multitude of utility crossings, and work along steep slopes with limited access all pose increased safety risks to our crews and the public. Our team will coordinate with necessary stakeholders and our internal safety team to create thorough site and task-specific safety plans and communicate them with crews daily.

**NATIVE SOIL CONDITIONS ALONG ALIGNMENT:** Based on internal potholing operations, areas along the alignment contain both suitable sandy backfill material and unsuitable rocky material. In areas with unsuitable materials, Tapani will set up screening and borrow pit operations to ensure backfill material meets specifications. For the Jack and Bore operation, encountering boulders is a probable risk. Our team will work alongside our boring subcontractor to find the safest and time efficient methods for completing the casing under HWY 730 should these conditions arise.

**LIMITED EASEMENTS & ACCESS:** Easement width along the alignment varies and will require pre-planned coordination of materials and equipment. This is most critical for the steel alignment from the pump station to the WEID canal, which will require proactive communication and coordination with impacted homeowners. For phase 1 & 2 FRP alignment extending through farmlands and Depot property, communication has already been established for permissions for material staging, access, water sources, utility locates, and impact to operations during open-cut road crossings.

**PROCURING A WATER SOURCE FOR FIRE PREVENTION AND COMPACTION:** With brush fires and dust control a significant concern, Tapani will have a 3,000 gallon water truck within ¼ mile of any active construction zones. Two separate water sources within 2.5 miles of the project have been identified and can be utilized as required for dust control/backfill compaction efforts & fire prevention. Locations: City of Umatilla fire hydrant located at 45.893689,-119.346443 and Grimmway water well source located at 45°52'44.6"N 119°21'14.7"W

**BURIED UTILITIES:** Tapani will work with landowners to identify any undocumented underground utilities. Tapani will also pothole to verify location of existing petroleum lines, internet/telephone lines, power distribution lines, and existing irrigation pipelines.

**HISTORIC WEID CANAL CROSSING:** The steel pipeline extension over the existing historical WEID canal will require the demolition of an existing wall by hand work only and the construction of three new support walls. The canal will be protected during construction with foam pads and plastic coverings.

**WILLIAMS GAS LINE OPEN-CUT CROSSING:** Tapani will pothole and hand dig around the Williams Gas Line and any other gas lines to ensure a safe casing / carrier pipe installation.

**PUMP STATION SITE:** Pump station design finalization will need to be completed as soon as possible so that all materials can be ordered and procured in a timely manner. Construction will include site grading, underground utility work (airburst pipelines, steel discharge piping & flow meter vault, and electrical), self-performed erection of the electrical building, placement of the surge tank requiring a crane, remaining pump station components, and radio tower construction.

#### **TIMELY OBTAINMENT OF PERMITS:**

##### **A. Owner Supplied Permits/Easements**

1. Umatilla County Road Crossing Permits
  - Contractor to supply all necessary bonds and traffic plans.
2. Oregon Department of Transportation (ODOT) Road Crossing Permits
  - Contractor to supply all necessary bonds and traffic plans.
3. West Extension Irrigation District (WEID) Canal Crossing Permit
4. Pipeline Easements
5. BPA Transmission Line Crossing Permit
6. Williams Gas Line Crossing Permit

##### **B. Contractor Supplied Permits/Easements**

1. Building Permit: 12 Week Turnaround
2. Electrical permit: Day-Of Release
3. HVAC Permit: 1 Week Turnaround

#### **The role of Tapani in meeting project goals:**

1. **Provide an experienced and local team** that can deliver what they promise. Based out of Tapani's tri-cities office, Blaine Bellikka, Shane MacArthur, and Kurt Cichosz bring their successful experience with East Irrigation District's large irrigation projects, DNR's Paterson Pipeline and Pump station upgrades, and Echo pipeline, among others described in more depth later on.
2. **Work collaboratively with Umatilla County/IRZ** to provide design recommendations that align with both current and future needs.
3. **Provide the right team, equipment, manpower, and pre-planning** to safely build the project on time, with quality workmanship, and within budget. We have dedicated five crews to this project, with capacity to add more if needed.
4. **Uphold our work: provide quick, reliable, and quality warranty repairs** for two years after completion, with additional services available as needed. At the end of the day, we care about ensuring a working system and will do what it takes to maintain that for however long, no matter what is at fault.

# 5.3 MINIMUM QUALIFICATIONS

## 1. Tapani's CCB License



## 2. 10 Years Successful Experience with Similar Projects

**Table 2: 10 YEARS OF SUCCESSFUL EXPERIENCE CONSTRUCTING SYSTEMS OF THE SAME SIZE AND SCOPE**

PHOTO	YEAR	PROJECT	\$	OWNER
	2007-2008	MP 23.7 Reservoir	\$5.1M	Sunnyside Valley Irrigation District

The MP23.7 Reservoir project required the construction of a 25 acre, 500 acre foot capacity (163 million gallons) irrigation reservoir used for enhancing the irrigation district's water usage performance. This project included the excavation of 700,000 cubic yards of material, 300,000 cubic yards of dam embankment, installation of 11,000 feet of under drain piping, and liner. Two concrete control structures were constructed and equipped with electric motorized slide gates, along with a pump station that held four vertical turbine pumps attached to a 60" steel header pipe. This project had difficult moisture tolerances to obtain - the existing material was at 2% and placed material was required to be at 17%. This required a wetting process requiring 65 gallons of water per cubic yard of soil while maintaining a production rate of 15,000 cubic yards per day. Design errors in the inlet structure resulted in a canal breach and filled the reservoir before construction was complete, ruining the entire sub-grade and a loader in the bottom. Tapani was able to get four, 12" pumps on site in less than eight hours, with the entire reservoir pumped out within a couple of days.

	2011-2012	Enclosed Lateral Improvement Project	\$1.1M	Sunnyside Valley Irrigation District
--	-----------	--------------------------------------	--------	--------------------------------------

This project served as a water conservation project encouraged by the department of ecology. A low head lateral system with weir boxes was replaced with gravity pressure pipe and flow meters. Tapani installed 18,900 linear feet of 4"-27" PVC in existing canals traversing through agricultural areas and across several county roads. The completion of this project resulted in increased water availability due to reduced evaporation and seepage losses, as well as a nearly complete removal of sediment deposits and pesticide contamination to the irrigation water due to agricultural run-off. All work was completed in the "off season" to limit disturbance to farming operations and required precise material coordination to ensure that the main line crew's productivity was not hampered by material staging.

	2011-2012	Gearhart	\$1.1M	City of Gearhart
--	-----------	----------	--------	------------------

Tapani performed all of the structural concrete work on this project including the erection of a 550,000 gallon Clearwell tank utilizing a columnar support roof, a 200,000 gallon backwash tank, and the foundation for a 1-million gallon water reservoir.

	2014-2015	MVID In-Stream Flow Improvements	\$1.7M	Trout Unlimited
--	-----------	----------------------------------	--------	-----------------

The MVID East Canal was an open irrigation canal extending south from the point of diversion on the Methow River for approximately 9.5 miles. This project replaced a portion of the canal with a gravity pressurized piped system beginning at Mill Hill and extending down to a drain near Beaver Creek. The piped system included 23,590 feet of 24-26" HDPE irrigation pipe, supplying water to over 150 parcels. With the possibility of extending the East Canal pipe up to the existing Methow River diversion in the future, the pipe design considered the pressures that would result when the canal was piped along this entire length.



**2014-2016**

**Discovery Corridor Wastewater  
Transmission System Phase 1**

**\$20M**

**Clark Regional Wastewater  
District**

The District Capital Improvement Program Project No.27-2013-0016 provided the City of Ridgefield future expansion capabilities by increasing the City’s sewer capacity. Work included modifying the existing pump stations to support the addition of 64,000 feet of 3”-30” HDPE sewer force mains and gravity pipelines. Along the alignment crews installed 44 manholes, 13 air relief vaults, four pump stations, and odor control systems. Tapani also self-performed the construction of a concrete masonry building to house all mechanical/electrical controls. Pipeline construction required a total of five Jack & Bores ranging from 18”-48” in diameter- three of which were underneath Interstate 5, and 700 feet of 16” and 22” parallel directional bores.



**2016-2018**

**Hancock and Calligan Creek  
Hydroelectric Projects**

**\$28.6M**

**Snohomish County PUD**

The Hancock Creek and Calligan Creek Hydroelectric projects coincided to construct two, run-of-the-river hydroelectric facilities for Snohomish County. Situated in 89,500 acres of timber forest lands, thorough pre-planning and coordination was critical to accommodate the extremely remote location, environmentally sensitive work areas, and steep terrain. Crews started with the construction of diversion structures in the local stream, directing existing flow from the stream to sluice-way channels. Next, crews cleared land for a one-way contractor-designed haul road along the pipe alignment within extremely limited easements. The new pipe alignments included 5,940 feet of butt-fusion welded HDPE pipe, 550 feet of 45” welded steel pipe, 3,285 feet of 41” welded steel pipe, and 4,110 feet of 39” welded steel pipe in deep trenches requiring specialized shoring and dewatering. Teams also constructed a stream diversion in order to install a concrete cast-in-place weir system directing future water flow towards the hydroelectric facility.



**2018-2019**

**Sutherlin Wastewater Treatment  
Plant**

**\$16.7M**

**City of Sutherlin**

This project included the addition of a four-basin 2,000,000 + gallon sequencing batch reactor with all new influent components including: new influent wastewater screens, influent pump station with five 1800 gpm pumps, head works facility, two tertiary filters, new ultraviolet disinfection facility, new wood framed electrical room, CMU dewatering/biosolids room that house a dewatering screw-press skid and associated parts, remodel of existing laboratory and garage, rehabilitation to existing aerobic digester tanks, new effluent recycled water pump station and of-site pump station rebuild. Crews also installed mechanical piping and specialty equipment while overseeing the interior finishing of the new structures (blower facility, biosolids dewatering facility, and electrical facility) in the northwest corner of the job site.



**2020-2021**

**Salmon Creek Wastewater  
Treatment Plant - Phase 5**

**\$8.18M**

**Clark Regional Wastewater  
District**

Construction included new odor control facilities, oil storage building, demo of existing building, modifications to existing aeration basins, yard piping, process piping replacement, small hypochlorite feed system, new enclosure around existing waste gas incinerator control equipment, and a new canopy over ultraviolet disinfection equipment. Work also included maintenance and modifications to one aerobic digester and a 2nd anaerobic digester, replacement of one bio-solids cake screw conveyor, replacement of two boiler exhaust stacks, installation of digester gas blower equipment and piping, and replacement of HVAC in Buildings 70 & 72.



**2019-2022**

**Northside PUD Water Reservoir  
and Booster Pump Station**

**\$4.2M**

**City of Washougal / Tower  
Development**

Tapani/Windsor Engineers lead the design-build efforts for the Northside Water Reservoir and Booster Pump Station, which expanded the City of Washougal’s water supply to accommodate it’s significant residential growth. This required the design and construction of an 827,000 gallon standpipe reservoir and a booster pump station providing water at 1,685 gpm to supply the City’s expanding development to the area. The standpipe reservoir was 44 feet in diameter and 76 feet high, welded steel, epoxy coated shell, and required a rammed aggregate pier foundation beneath the footprint and ring wall. The booster pump station contained the electrical controls along with the piping and pumps. A monorail crane was also installed within the pump station. The booster pump station required thorough design for specialty electrical, instrumentation and controls, and an emergency generator.

## 2. Five Years Of Successful Experience with FRP & Steel Mainlines

Table 3: FRP & STEEL PIPELINE EXPERIENCE

YEAR	PROJECT	OWNER	\$	PIPE	DIA.	LF
2015	NSID - Main Canal Flumes Replacement	Naches-Selah	\$6.13M	FRP	96"	3,600
2016	Regional Water Recycle & Reuse Project	Port of Morrow	\$1.46M	FRP	30"	80,000
2019	EID Steel Pipeline - ITB 201	East Irrigation District	\$1.61M	Steel	66"-78"	3,790
2019	EID FRP Pipeline - ITB 202	East Irrigation District	\$7.49M	FRP	66"- 75"	42,500
2019	DNR Paterson Pipeline	Frank Tiegs LLC	\$5M	Steel	30"	4,400
2019	St. Hilaire Bro Columbia River Pipeline	St. Hilaire Brothers	\$998K	FRP	42"	9,500
2020	PLW_1.3 Farmington Road to Kinnaman Road	Willamette Water Supply Program	\$28.9M	Steel	66"	6,325
2020	Ice Harbor Phase 2C	Hancock Natural Resources Group & JJW Cranberries LLC / IRZ Consulting	\$1.9M	GRP	48"	10,800
2020	Hillside Phase 2C	Hancock Natural Resources Group & JJW Cranberries LLC / IRZ Consulting	\$2.08M	GRP	48"	3,080
2020	Butter Creek Water Development	Agri-Northwest	\$1.7M	FRP	36"	46,650
2021	Echo Pipeline	Agri-Northwest	\$296K	FRP	66"	10,000
2021	Boardman North 36" Replacement Pipeline	Willamette Water Supply Program	\$197K	FRP	36"	9,530
2022	PLM_4.4 Chicken Creek to Borchers Drive	Washington County / Willamette Water Supply Program	\$17.7M	Steel	66"	3,035
2022	PLM 4.3 Pipeline Transmission Main	Willamette Water Supply Program	\$47.6M	Steel	66"	13,215
2022	PLW 1.2 TV HWY to Frances St	Washington County / Willamette Water Supply Program	\$21.5M	Steel	48"	3,850

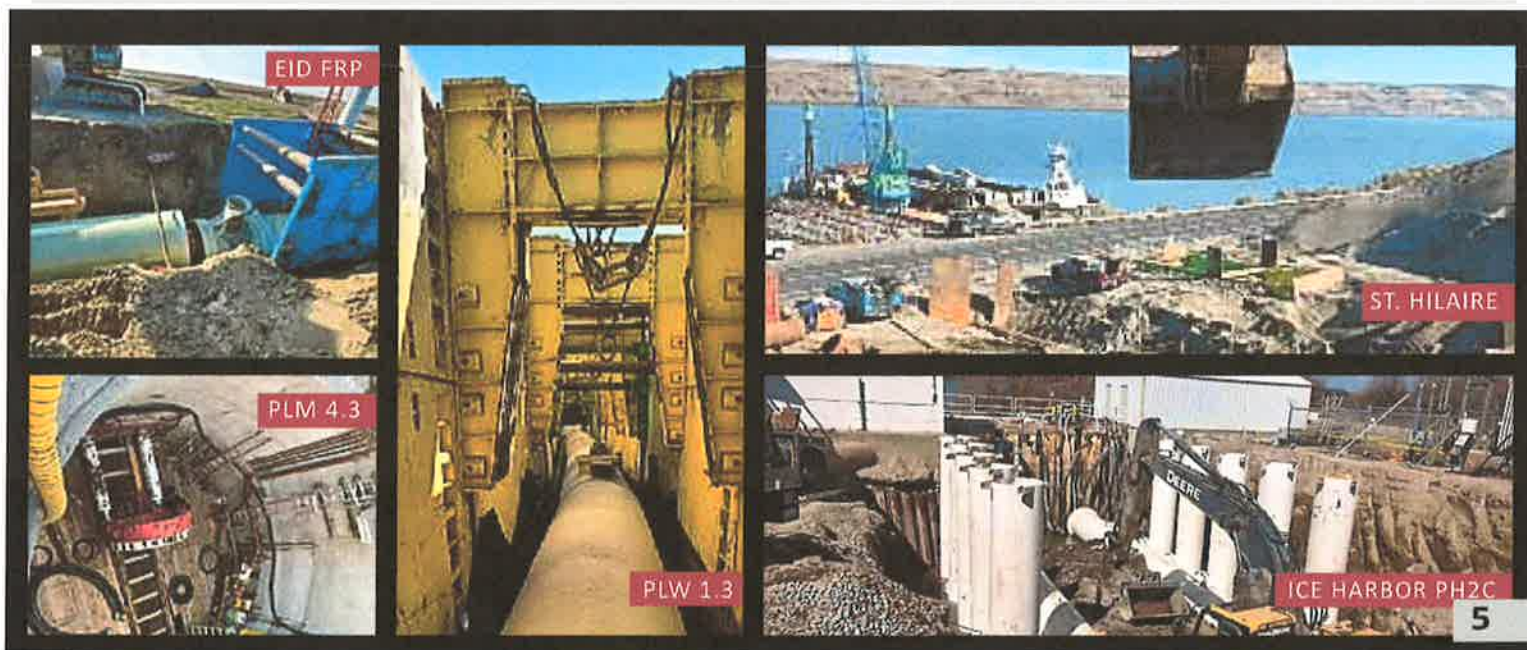



## 5.4.1 COMPANY EXPERIENCE

### 1. Tapani's History

Since 1983, Tapani has grown from a grass-roots, single-family business to a thriving team of over 500 employees located out of our Battle Ground, Tri-Cities, and Sherwood offices. As our team has grown and diversified significantly, so has our ability to construct varying categories of projects. Initially specialized in the construction of underground utility work, our capabilities now include both design-build and design-bid-build in five different markets: Civil Site Development, Buildings, Transportation, Utility Infrastructure and Environmental. With our employees, community, and a continuous attitude of excellence at the heart of our business, we are passionate about partnering to build quality projects that matter.

We have found that the most successful projects are those founded on mutual trust, transparency and collaboration- where it is established early on that everyone is on the same team. Our project teams strive to build projects that collectively utilize the experience of all partners to design, build, and overcome all challenges from concept to completion. Over the years, we have taken pride in providing value engineering concepts that provide cost savings, increased confidence in constructibility processes, quality, and that maximize the unique opportunities of the purpose and setting of every project. The references below represent some of our most successful business partnerships and projects; success was found by sharing the mutual goals of a trusting and collaborative partnership, leading to overall project success.

### 2. Company References

COMPANY	ASSOCIATED PROJECTS	CONTACT NAME	CONTACT
Tower Development Inc.  (Total Contracted \$4.7M)	Northside PUD Water Reservoir & Booster Station  Shepherd Road - Lift Station 8 Upgrades	David Lampe  (Owner)	(360) 772-2685
Clark Regional Wastewater District  (Total Contracted \$45M)	Discovery Corridor Wastewater Transmission System Phase 1 Salmon Creek Treatment Facility Regional Biofilter Upper Kline Line Interceptor Ridgefield WWTP Repairs Pleasant Valley North Pump Station North Junction Pump Station and Trunk Pioneer Street Sewer Extension CRWWD District Campus Improvements NE 99th Street Trenchless Pipe North Junction Lateral	Ron Monteferrante  (Construction/Project Manager)	(503) 880-5318
East Improvement District (Total Contracted \$13.8M)	East Irrigation District Contract 1 East Irrigation District Contract 2 East Irrigation District Contract 3	Wayne Downey  (Owner's Representative)	(208) 995-5125
Willamette Water Supply Program  (Total Contracted \$139M)	PLW_1.2 TV HWY to Frances St PLW_1.3 Farmington Rd to Kinnaman Rd PLM_4.3 Roy Rogers Rd PLM_4.4 Chicken Creek to Borchers Dr PLM_5.1 North of Beef Bend Rd to Scholls Ferry Rd	Andre Tome  (Program Construction Manager)	(925) 360-0646

### 3. Three Key Company Projects

## EID EAST PROJECT CONTRACTS 1-3

Hermiston, OR

**Owner:** East Improvement District

**Reference:** Wayne Downey, 208-995-5125, wayne.downey@irz.com

**Contract Amounts (Combined):** \$13.85M

**Contract Duration:** Sep. 2019 - Sept. 2020

**Project Team:** Tod Tapani (Project Principal), Blaine Bellikka (Project Manager)

**PROJECT PURPOSE** Spanning eight miles from the Columbia River Gorge into Northeast Oregon's Umatilla Basin- home to some of the state's most productive farmlands, the East Irrigation Project was the first of three long-awaited mass irrigation lines to be constructed under the Northeast Oregon Water Association (a nonprofit corporation founded to develop solutions to the basin's water shortages.) Focused on decreasing the strain on underground aquifers by providing farmers with a secondary water supply, the East Project taps into the Columbia River east of Hermiston and runs approximately eight miles south to Despain Gulch, providing water to over 26,500 acres of farmland.

Working under the ownership of the East Improvement District – a public entity formed from 13 of the local landowners, Tapani managed all three work contracts of the East Project. Under the first contract (EID Crossings & Borings), Tapani partnered with Stadelli Boring to prepare the irrigation alignments- skillfully coordinating and installing seven different bores under Union Pacific railroads, major ODOT highways and roadways, and a major gas line.

#### CONTRACT 1: EID CROSSING & BORING PIPELINE

With the new pipe alignment extending miles from a Columbia River tie-in near Hermiston, OR to Despain Gulch, Tapani and Stadelli performed the first of seven bores under ODOT's Highway 237, running right along the bank of the Columbia River. This required an 84" bore and 48" bore to connect the future pipeline to the existing Columbia River pump station. Working inland up the hillside, the next two 84" and 48" bores were constructed under the active Union Pacific Railroad (UPRR) railroad track running the length of Oregon's Columbia River Gorge. To minimize work time around the railroad and lower the risk of potential delays, Tapani worked closely with MGS and UPRR to coordinate and complete all of the railroad bore work in 15 days, working in 24-hour supervised shifts. The next two 84" and 48" bores were drilled under Highway 37. The final 76" bore was drilled under two county roads and a Williams natural gas line, requiring heavy coordination with the utility company to ensure all additional safety standards were met.



**GROUND CONDITIONS** – Encountering greater quantities of sandy soils than predicted along the railroad track created unforeseen conditions with the ground sloughing in the bore areas. Working together as a team, Tapani, UPRR and EID found a time-efficient solution by bringing on Budinger & Associates as a consultant. After evaluating the geotechnical conditions, Budinger performed formation grouting of the bores by drilling over the bore casing and injecting grout into the sandy soil, effectively mitigating the risk of caving or settling ground under the railroad.





**CONTRACT 2: WELDED STEEL PIPE** Under the second contract, Tapani constructed 3,636 feet of owner-supplied 78" welded steel pipeline and 154 feet of 66" welded steel pipeline that both tied into the existing Columbia river pump station. These steel pipelines were installed at 10- 15 foot depths and required trench boxes and dewatering due to the wet ground encountered along the Columbia River. Crews utilizing a straw (external wet well) system and pumps in the trench boxes. Tapani also encountered hard rock obstructing areas of the pipe alignment that resulted in 4,500 cubic-yards of blasted and crushed material.

**CONTRACT 3: FIBERGLASS PIPE** Under the third and final contract, Tapani assembled the remainder of the irrigation line, stretching through acres of farmland from Despain Gultch and tying in the welded steel pipelines 3,600 feet from the Columbia River. The majority of the irrigation line was designed utilizing 66" - 75" fiberglass pipe (FRP); crews installed over eight miles (42,500 feet) of FRP irrigation line in total. Of this, approximately 10,655 feet was 66" (Class 150); 22,500 feet was 72" (Class 150); 7,870 feet was 72" (Class 200); 1,465 feet was 72" (Class 250); and 70 feet was 75". Requiring placement in areas of extremely rocky ground, Tapani partnered with Fortis & Smith to blast over 14,000 cubic-yards of material.

**COORDINATION WITH LANDOWNERS** Communication and coordination with local land owners (who had active farming operations ongoing throughout construction) was critical to planning a schedule that minimized impacts to the local work economy while also minimizing Tapani's risk of running into unmarked underground utilities. Collaboration with individual land owners provided the local knowledge of the land (unmarked utilities) that was key to continuing a steady operation and finishing the entirety of the East Project in under a year.

**SCHEDULE** Faced with owner-supplied pipe delivery delays, challenging ground conditions, and a complex pipe staging operation, EID worked with Tapani's team to accelerate pipe installation by using five crews instead of the normal two to three. This solution effectively made up the delay times while also putting more of Tapani's crews to work during the winter. Utilizing additional crews also helped with the complex pipe staging operation which required three unloading operations to unload each Connex box of pipe from UPRR rail cars and deliver it to where it was needed along the pipe alignment. The coordination of all five crews and complex pipe delivery and staging was by far the largest accomplishment for this contract, especially with coordination being so collaborative between EID, UPRR, and the farmers impacted by the pipe alignment.



#### SIMILARITIES TO ORDNANCE PROJECT

- Welded Steel Pipe
- Reinforce Fiberglass Pipe
- Bore Under Major Highway
- Coordination with Landowners was key to access & utility locates
- Schedule dependent on Farming schedules
- Rocky conditions & winter work
- Working in partnership with IRZ
- Tie-In to resisting pump station on Columbia River



# DEPARTMENT OF NATURAL RESOURCES PATERSON PIPELINE

Sutherlin, OR

**Owner:** Frank Tiegs LLC

**Reference:** Jim McClellan, 509-521-5508

**Contract Amount:** \$5,08M

**General Contractor:** Tapani Inc.

**Contract Duration:** October 2018 – March 2019

**Project Team:** Tod Tapani (Project Principal), Blaine Bellikka (Project Manager)

**PROJECT BACKGROUND** The DNR Paterson Pipeline was a long-term private investment aimed at preserving the \$41 million in water rights that the Department of Natural Resources would have lost in 2020. The pipeline provides over 3,000 acres of irrigation to public agriculture land, significantly boosting local economic growth, and quadrupling the revenue generated by the land for Washington public schools.

**UPGRADES TO EXISTING PUMP STATION** Tapani upgraded the existing pump station at the Columbia River by installing a new manifold, new steel pipe networks and valves, and new electrical systems. In addition, three 60-inch pipe pumps were installed connecting to the Columbia River. To prevent major water surges, Tapani partnered with Pulsco, a leading provider of fluid pulsation, noise, and surge control solutions, to design and build a surge-protection tank system. The surge-protection tank system was crucial to ensuring the safety and longevity of the pipeline, as it helps to prevent damage from water surges that can occur during periods of heavy rainfall or irrigation. This system also included the self-performed construction of a small CMU utility building to house the air bladder system.

**NEW IRRIGATION LINES** After completing the pump station upgrades and surge-protection building, Tapani dedicated two crews to the construction of the irrigation line. Despite challenging terrain and the need to coordinate with local farmers to minimize disruptions to their schedules, Tapani's crews averaged between 1,000 and 3,000 linear feet of pipe installation per day. This included a total of 49,761 linear feet of irrigation line installation: 4,400 feet of 30" welded steel pipe that included a major gas line crossing and 45,361 feet of 30-inch C900 PVC pipe with associated drain valves and ARV assemblies.

**TIGHT SCHEDULE** Extending from the Columbia River in Southeast Washington to the Horse Haven Hills north of Paterson, WA, Tapani's two crews completed the construction of the 8-mile long irrigation pipeline and pump station upgrades in under six months.

## SIMILARITIES TO ORDNANCE PROJECT

- Irrigation Expansion investing in local agricultural economy & Tying into Columbia River
- Pump Station: Electrical Components, Manifold, Pumps, Surge Protection Tank, Self-Performed Building construction
- Welded Steel Pipe Installation
- Existing Utilities: Gas Line Crossing, underground electrical utilities, overhead power lines,
- Coordination with Landowners was key to access & utility locates
- Schedule highly dependent on farming schedules
- Boulders / Rocky ground conditions
- Working in partnership with IRZ



# SUTHERLIN WASTEWATER TREATMENT PLANT IMPROVEMENTS

Sutherlin, OR

**Owner:** City of Sutherlin

**Reference:** Jamie Norrington, 541-459-4619

**Contract Amount:** \$16.7M

**Contract Duration:** May 2018 - May 2019

**Project Team:** Tod Tapani (Project Principal), Zane Shaut (Project Manager)

**PROJECT BACKGROUND** Originally constructed in 1956 and updated in last in 1977, the Sutherlin Wastewater treatment plant was not meeting the current National Pollutant discharge Elimination System limits, specifically it's total maximum daily load limitations. Located in rural Southern Oregon, Tapani updated and expanded the existing plant, increasing the daily treatment capacity of the plant while improving the quality of the treated water as an end product.

**PROJECT SCOPE** This project included construction of a four-basin, 2,000,000+ gallon sequencing batch reactor with new influent components. The components included new influent wastewater screens, influent pump station with five 1,800gpm pumps, a head works facility, and two tertiary filters. Utility installation included a new 16" force main connecting the influent pump station to the head works. Tapani's structural team also constructed an ultraviolet disinfection facility, wood framed electrical room, new effluent recycled water pump station, and a CMU de-watering/bio-solids room. Some of the remodeling work included a remodel of existing laboratory and garage, rehabilitation to existing aerobic digester tanks, and an off-site pump station rebuild. Crews also installed mechanical piping and specialty equipment while overseeing the interior finishing of the new structures (blower facility, biosolids de-watering facility, and electrical facility). These improvements increased the daily treatment capacity from 1.3MGD to 7.0MGD and improved the quality of the treated water.

## PROJECT ACCOMPLISHMENTS

Tapani crews completed the construction of the head works structure, which posed as a very challenging structure involving heavy planning and coordination prior to construction. With live sewer lines flowing at high volume, crews had to plan and construct a diversion flow line to subsequently construct the required falsework, forming, and support of the Head works structure. Ensuring that all sections of the building would perform as needed took time, diligence, and quality assurance prior to every part being constructed.

## SIMILARITIES TO ORDNANCE PROJECT

- Limited site access around in-use Facilities with many existing underground utilities
- Structural concrete work: foundations, walls, etc.
- Headworks facility connecting to 5 pumps
- Self-performed building erection
- Heavy electrical components
- Heavy mechanical piping
- Coordination of multiple facilitates / phases constructed within a limited window



## 5.4.2 PROJECT TEAM & EXPERIENCE

### 1. Our Dedicated Team

Based out of Tapani's Tri-Cities office, the dedicated management team below brings a combined 155 years of successful and passionate experience in the construction of fast-paced large diameter pipeline installations, mass earthwork projects, mechanical, concrete, and vertical projects.

**WEEKLY DESIGN INPUT & EARLY PROCUREMENT** Aaron Halling (Design Assist), Shane MacArthur (Project Manager), Blaine Bellikka (Regional Manager), and Kurt Cichosz (Superintendent) will be the primary team providing constructibility input and design reviews as Umatilla County and IRZ finish final designs of the pump station and alignment through the end of the year. Aaron Halling brings an engineering background with in depth experience in project management and estimating. Blaine brings a positive working relationship with IRZ and extensive local experience. And Kurt brings out-of-the-box thinking and a practical understanding of what's needed to move the project from design to construction.

**MANAGEMENT** Tod Tapani, as Project Principal, will ensure all manpower and equipment needs are met and serve as an additional point of contact for Umatilla County. Shane McArthur, Project Manager, will oversee the entire two phases of the project, working directly with John Shafer and Ty Lord to ensure the project progresses on schedule while meeting the critical safety and environmental requirements. Zane Shaut, Structural Project Manager, will specifically oversee the concrete and PEMB erection at the pump station site. Craig Schmitt, Procurement Lead and Project Engineer, will provide his 18 years of experience in pipeline distributions to ensure timely procurement of materials and will oversee all subcontract and supplier management.

**CONSTRUCTION** Kurt Cichosz, Project Superintendent will oversee the daily management of tasks, ensuring productions that are in-line with the project schedule and providing two-week schedule updates throughout the project. Kurt will direct all on-site crews and equipment to ensure critical path items are safely completed on time with quality assurance.

**SAFETY & ENVIRONMENTAL COMPLIANCE** Elle Bucho will oversee the site and environmental safety compliance throughout the project. This will include working with Kurt to provide a site specific safety plan, task specific safety plans, that erosion and sediment control is in compliance during any big rain events, and that adequate measures are taken to ensure environmental safety with pump station construction near the Columbia River.

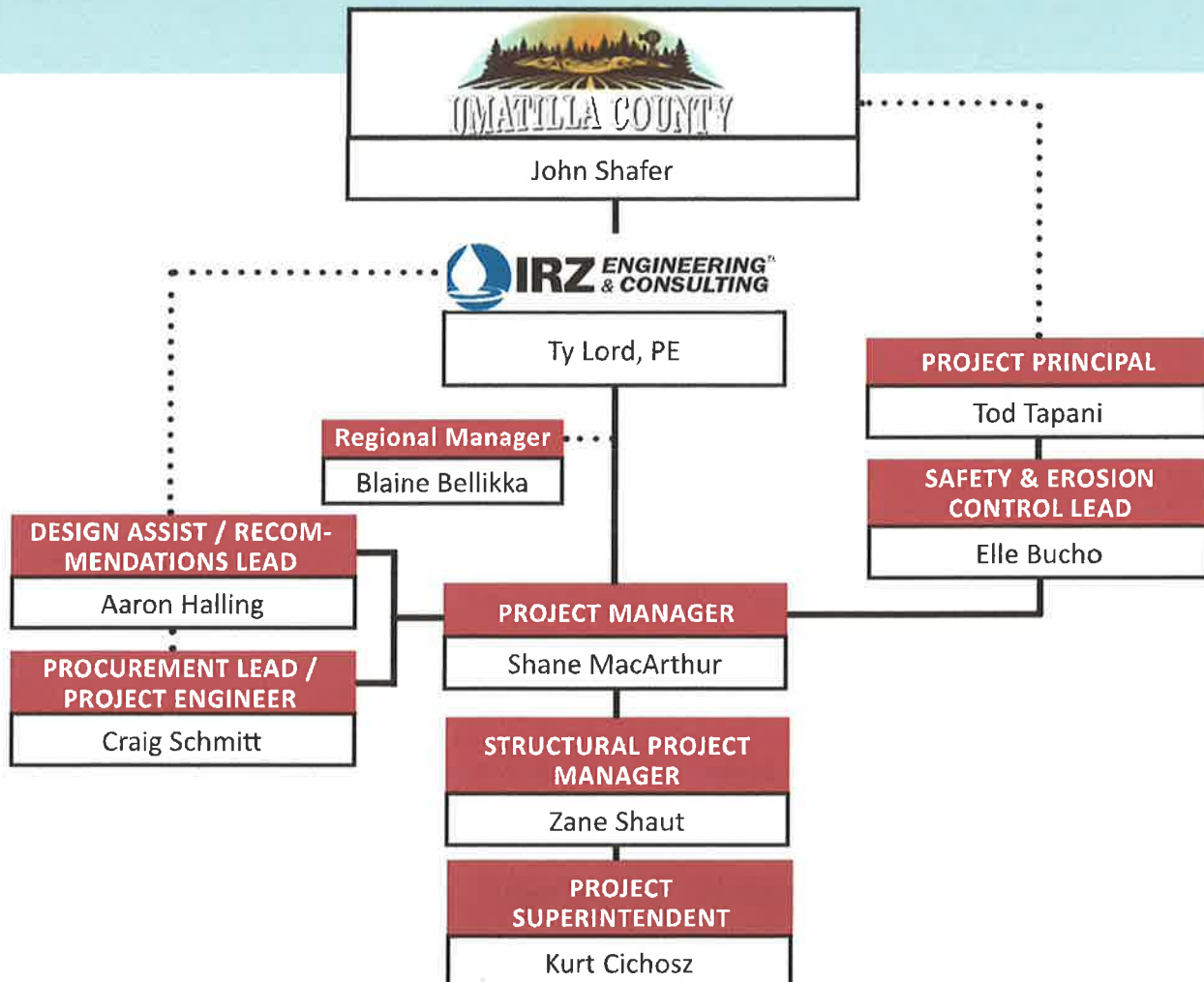



## TOD TAPANI OWNER / PROJECT PRINCIPAL

As one of Tapani's second-generational owners, Tod is highly invested in developing long-term industry relationships, ensuring the success of Tapani's project and sales teams, overseeing big-picture project schedules and resources, and inspiring a top-down adoption of Tapani's core values in every part of the company. With 22 years of in-depth experience in both the field and management positions, Tod's passion lies in utilizing his experience to inspire teams to lead with integrity, clear communication, and thorough pre-planning to ensure long-term success on every project.

### YEARS OF EXPERIENCE

22

### CERTIFICATIONS / TRAININGS

Trenching & Excavation Competent Person, Confined Space Competent Person, CPR & First Aid, P6 Schedule, Microsoft Suite, Blue Beam 2 D Design, Fieldwire, HCSS Heavy Job, Leadership Development Lab, HCSS HeavyJob & HeavyBid, Viewpoint Construction Software Vista, Trimble ProjectSight, Fieldwire

### KEY PROJECT EXPERIENCE

- \$26M** Hancock & Calligan Creek Hydroelectric Projects, Snohomish County PUD (Project Principal)
- \$16.7M** Sutherlin Wastewater Treatment Plant Improvements, City of Sutherlin (Project Principal)
- \$8.1M** Salmon Creek Treatment Facility, Clark Regional Wastewater District (Project Principal)
- \$7.4M** EID FRP Pipeline Contract 3, East Irrigation District (Project Manager)
- \$6.6M** River Terrace South Pump Station & Force Main, Clean Water Services (Project Principal)
- \$4.9M** Battle Ground Flow Equalization, City of Battle Ground (Project Manager)
- \$4.7M** EID Boring & Crossings Contract 1, East Irrigation District (Project Principal)
- \$4M** DNR Paterson, Frank Tieggs (Project Principal)
- \$3.4M** Process Water Reuse Facility Utility Expansion Phase 1, City of Pasco (Project Principal)
- \$2.5M** East Lents Floodplain Phase 2, City of Portland (Project Manager)
- \$2.5M** East Lents Floodplain Phase 1, City of Portland (Project Manager)
- \$2.1M** Benton Irrigation 3B Work, Benton Irrigation District (Project Manager)
- \$1.7M** Butter Creek Water Development, Agri Northwest (Project Principal)
- \$1.6M** Entiat to Canal Waterline, City of Kennewick (Project Principal)
- \$1.6M** EID Steel Pipeline Contract 2, East Irrigation District (Project Principal)



## ELLE BUCHO SAFETY & EROSION CONTROL LEAD

Elle brings over 5 years of experience in construction to Tapani's Tri-Cities office, with expertise in financial tracking and management, job site safety planning and implementation, erosion control planning and implementation, and subcontract management. She is passionate about building reliable and trusting relationships with all stakeholders, with her primary goal to provide the unique resources and support necessary to ensure that every projects maintains alignment with the overall Owner/ Stakeholder goals. Elle is currently responsible for managing project submittals, subcontracts, task and financial tracking, leading job site safety planning and job site safety walks, and implementing and managing erosion and sediment control methods, forms, and compliance.

### YEARS OF EXPERIENCE

5

### CERTIFICATIONS

CPR & First Aid Certified, OSHA 30, Certified Erosion and Sediment Control Lead, CPR Certificate

### KEY RESPONSIBILITIES

- Create and Lead JHA's, Daily Pre-task Plans, Toolbox Talks, Stretch-and-Flex
- Inspection for pre-check lists on equipment
- Coordinating with safety inspectors & OSHA on safety audit walks
- Write/implement task specific safety plans
- Coordinate with utility owners to identify utility hazards
- Host post action reviews to determine RCA
- Provide and lead safety trainings for confined spaces and trench zones
- Procure Erosion Control Materials
- Erosion Control Reports
- Erosion Control Maintenance and Repair



## BLAINE BELLIKKA Regional Manager

Blaine started his career at Tapani in 2006 and quickly became an integral part of the company's management team. Over the years, he has played a key role in Tapani's expansion into the Tri-Cities Area/Eastern Washington and Oregon. In 2018, Blaine relocated his family to the Tri-Cities area to manage Tapani's large-scale irrigation projects in the region. He was instrumental in opening Tapani's first regional office in the area in 2019. With 16 years of experience at Tapani, Blaine has gained in-depth knowledge of construction and construction management for large utility projects. He has worked in various roles, including foreman, pipe layer, project manager, and Regional Manager, where he oversees all projects and personnel. Blaine is committed to exceeding expectations on every project and takes pride in building positive and trusting relationships with owners/clients, subcontractors, and suppliers.

### YEARS OF EXPERIENCE

12

### CERTIFICATIONS / TRAININGS

Trenching & Excavation  
Competent Person, Confined  
Space Competent Person  
CPR & First Aid, PG Schedule,  
Microsoft Suite, Blue Beam  
2-D Design, Fieldwire,  
Leadership Development Lab,  
HCSS HeavyJob & HeavyBid,  
Viewpoint Construction  
Software Vista, Trimble  
ProjectSight, Fieldwire,  
Autocad

### KEY PROJECT EXPERIENCE

- \$7.4M** EID FRP Pipeline Contract 3, East Irrigation District (Project Manager)
- \$4.7M** EID Boring & Crossings Contract 1, East Irrigation District (Project Manager)
- \$4M** DNR Paterson, Frank Tieggs (Project Manager)
- \$3.8M** POM Build Columbia River, Port of Morrow (Senior Project Manager)
- \$3.5M** Ten Mile Force Sewer Main, The West Park Company Inc (Project Manager)
- \$2.7M** Internet Parkway Utility Improvements, Port of Morrow (Senior Project Manager)
- \$1.7M** Butter Creek Water Development, Agri Northwest (Project Manager)
- \$1.6M** Entiat to Canal Waterline, City of Kennewick (Project Manager)
- \$1.6M** EID Steel Pipeline Contract 2, East Irrigation District (Project Manager)
- \$1.5M** Lift Station No.3, City of Hermiston (Senior Project Manager)
- \$1.5M** Well No.11 Well House, City of West Richland (Project Manager)
- \$1.4M** AgriNW BNSF Rail Crossing, Agri Northwest (Senior Project Manager)
- \$998K** St. Hilaire Bro Columbia River Pipeline, St Hilaire Brothers (Project Manager)
- \$732K** Snake River 24" FRP Outlet Connections, Snake River Orchards (Senior Project Manager)



## SHANE MCARTHUR GENERAL PROJECT MANAGER

With over 30 years of experience in construction, Shane has developed strong leadership skills, effective communication skills, and a deep understanding of planning, organization, and construction knowledge required for successfully managing heavy civil construction projects. Since joining Tapani in His specialty work involves managing projects worth around \$3-5M each year, with a primary focus on maintaining a safe project that is completed on schedule. Shane is also committed to building positive working relationships with every individual involved in each project. He believes that working as a team to pre-plan, evaluate challenges, and find potential gains in value engineering, schedule, and material resources can lead to successful and satisfactory projects for all team members.

### YEARS OF EXPERIENCE

30

### CERTIFICATIONS / TRAININGS

Trenching & Excavation  
Competent Person, Confined  
Space Competent Person,  
PG Schedule, Microsoft  
Suite, Blue Beam 2-D Design,  
Fieldwire, HCSS HeavyJob  
& HeavyBid, Viewpoint  
Construction Software  
Vista, Trimble ProjectSight,  
Fieldwire

### KEY PROJECT EXPERIENCE

- \$11.1M** Project Oyster, Ryan Companies US, Inc. (Project Manager)
- \$4.9M** Sienna Hills Phase 1 Pump station & Bermuad Road (Project Manager)
- \$3.8M** POM Build Columbia River, Port of Morrow (Project Manager)
- \$3.5M** PWRP Utility Extension, City of Pasco (Project Manager)
- \$3.1M** Zone 2 7th Street Transmission Main, City of Kennewick (Project Manager)
- \$2.9M** UAS Phase IV Industrial Park, City of Pendleton (Project Manager)
- \$2.8M** East UGA Sewer Expansion, City of Pasco (Project Manager)
- \$2.7M** Internet Parkway Utility, Port of Morrow (Project Manager)
- \$2.5M** Project Pearly/Oyster Off-site Improvements, Ryan Companies US, Inc. (Project Manager)
- \$1.5M** Lift Station No.3, City of Hermiston (Project Manager)
- \$1.4M** AgriNW BNSF Rail Crossing, Agri Northwest (Project Manager)
- \$1.2M** Sienna Hills Phase 2, The West Park Company, Inc. (Project Manager)
- \$732K** Snake River 24" FRP Outlet Connections, Snake River Orchards (Project Manager)





## ZANE SHAUT STRUCTURAL PROJECT MANAGER

After completing his Bachelor's degree in 2012, Zane hit the ground running when he started his career with Kiewit Bridge and Marine in 2013. Based in Hawaii, Zane earned three years of fast-paced experience as a Field Engineer assisting with the management of \$1 Billion in light rail and bridge work. Relocating to Washington in 2016, Zane started with Tapani as a Project Engineer focused on expanding Tapani's structural concrete portfolio. Since then, Zane has played a critical role in managing the construction of buildings, utility stations, bridges, and control buildings.

### YEARS OF EXPERIENCE

23

### EDUCATION

B.S. Construction Management, Central Washington University

### CERTIFICATIONS

Trenching & Excavation Competent Person, Confined Space Competent Person, CPR & First Aid, P6 Schedule, Microsoft Suite, Blue Beam 2-D Design, Fieldwire, HESB HeavyJob & HeavyBid, Viewpoint Construction Software Vista, Trimble, ProjectSight, Fieldwire, Autocad

### KEY PROJECT EXPERIENCE

- \$1B** Honolulu Light Rail Transit Project, Honolulu Authority for Rail Transit (Kiewit Project M.)
- \$135M** Tilikum Crossing Bridge, Trimet (Kiewit Project Manager)
- \$47.6M** PLM 4.3 Pipeline Transmission Main, WWSP (Structures Project Manager)
- \$28.9M** PLW\_1.3 Farmington Road to Kinnaman Road, WWSP (Structures Project Manager)
- \$21.5M** PLW 1.2 TV HWY to Frances Street, Washington County (Structures Project Manager)
- \$17.7M** PLM\_4.4 Chicken Creek to Borchers Drive, Washington County (Structures Project M.)
- \$16.7M** Sutherlin Wastewater Treatment Plant Improvements, City of Sutherlin (Project Manager)
- \$9.6M** Tapani Headquarters Building, Tapani Inc. (Project Manager)
- \$8.1M** Salmon Creek Treatment Facility, Clark Regional Wastewater District (Project Manager)
- \$8.3M** Pioneer Street Rail Overpass, Port of Ridgefield (Project Manager)
- \$5.2M** Industrial Pre-Treatment Lagoon, City of Vancouver (Project Manager)
- \$5.1M** Regional Biosolids Facility, City of Long Beach (Project Manager)
- \$3.8M** POM Build Columbia River, Port of Morrow (Project Manager)
- \$3.1M** Naches-Selah Lateral No.3 Improvements, Naches-Selah (Structural Project Manager)
- \$1.8M** Well No.7 Pump and Control Building, City of Prosser (Project Manager)
- \$1.6M** West Biddle Lake Dam Replacement, Columbia Springs (Project Manager)



## KURT CICHOSZ PROJECT SUPERINTENDENT

A passionately hard worker that's schedule driven and a "think outside the box" thinker, Kurt has excelled in his role as Superintendent for the past five years. Located out of Tapani's Tri-City office, Kurt's overarching goal for every project is to manage field resources to optimize daily productions, deliver outstanding quality, and ensure complete safety for Tapani crews, our clients, subcontractors and the public. From his commitment to training, developing, and ensuring the well being of each of his crew members to meticulously inspecting quality control of materials and equipment, Kurt delivers projects to critical milestones by proactively mitigating schedule and cost risks and openly communicating expectations with subcontractors and suppliers early on.

### YEARS OF EXPERIENCE

12

### EDUCATION

Associates Degree, Oakland Community College

### CERTIFICATIONS

OSHA 10, CPR & First Aid Certified, Rigging & Signaling Trained, Forklift Certified, ATSA Certified, Cross Trained in all Heavy Equipment Operation, GPS Set Up & Operation, CESCL Competent Person

### KEY PROJECT EXPERIENCE

- \$26M** Hancock & Calligan Creek Hydroelectric Projects, Snohomish County PUD (Super.)
- \$9.5M** Midway Logistics Center, Cornice Construction LLC (Superintendent)
- \$7.4M** EID FRP Pipeline Contract 3, East Irrigation District (Superintendent)
- \$5.9M** 11th Street CSO Separation, City of Astoria (Superintendent)
- \$4.7M** EID Boring & Crossings Contract 1, East Irrigation District (Superintendent)
- \$4.4M** Haydu Community Park, Port of Kalama (Superintendent)
- \$4.3M** Headquarters Landfill Cell 7, Cowlitz County DOPW (Superintendent)
- \$3.9M** HP Greenfield Mass Grading, HP Inc. (Superintendent)
- \$3M** Knott Landfill Cell 6, Deschutes County Department of Solid Waste (Superintendent)
- \$2.2M** Headquarters Landfill Cell 6, Cowlitz County Department of Public Works (Super.)
- \$1.6M** EID Steel Pipeline Contract 2, East Irrigation District (Superintendent)
- \$998K** St. Hilaire Bro Columbia River Pipeline, St Hilaire Brothers (Superintendent)



## AARON HALLING PUMP STATION DESIGN ASSIST

### YEARS OF EXPERIENCE

23

### EDUCATION

B.S. Civil Engineering, South Dakota State University

### CERTIFICATIONS

Associate Design-Build Professional (DBPA), Engineer in Training (EIT), Blue Beam 2-D Design, Fieldwire, HCSS Heavy Job, HCSS HeavyJob & HeavyBld, Viewpoint Construction Software Vista, Trimble ProjectSight, Fieldwire

Aaron's career began on the design side of civil construction where he utilized his first 5 years of his career to provide civil designs for community septic systems, rural roads, subdivisions, and commercial sites. With a thirst for actually seeing his projects come to life, Aaron switched his career to project management when he joined Tapani's team. Since starting his career in construction, Aaron has worked as a successful project manager, estimator, and design-build assistant, always delivering quality planning and organization skills, innovate ideas for cost and schedule savings, and collaborative problem-solving. Aaron is a firm believer that working as a team to pre-plan, overcome challenges, and find potential gains in Value Engineering/schedule/material resources at the forefront of every project produces the most satisfactory project outcomes for every partner involved.

### KEY PROJECT EXPERIENCE

- \$10M** USPS Distribution Center, Amazon/The Korte Company (Project Manager & Design Assist)
- \$8.1M** Salmon Creek Treatment Facility, Clark Regional Wastewater District (Estimator)
- \$7.6M** Sharpes Corner Vicinity Improvements Project, WSDOT (Project Manager)
- \$4.5M** La Center Middle School, Robinson Construction (Project Manager & Design Assist)
- \$3.4M** Lateral No.3 Improvements, Naches-Selah Irrigation District (Project Manager & Design Assist on following Phase)
- \$2.9M** Carolina Pump Main Phase 2, City of Portland (Project Manager)
- \$2.7M** Prairie Electric - Ridgefield, Prairie Electric (Project Manager)
- \$1.5M** ASR-1 Well, City of Kennewick (Project Engineer)
- \$1.2M** S 38th Ave Improvements, City of West Richland (Project Engineer)
- \$617K** Washougal Wastewater Expansion Pump Stations 2 & 3, City of Washougal (Project Manager)



## CRAIG SCHMITT PROCUREMENT MANAGER/ PROJECT ENGINEER

### YEARS OF EXPERIENCE

23

### CERTIFICATIONS / TRAININGS

Trenching & Excavation Competent Person, Confined Space Competent Person, CPR & First Aid, P6 Schedule, Microsoft Suite, Blue Beam 2-D Design, Fieldwire, HCSS HeavyJob & HeavyBld, Viewpoint Construction Software Vista, Trimble ProjectSight, Fieldwire

Craig joined Tapani's team in 2019 after a successful 18-year career in the distribution of waterworks with Core and Main. Realizing he wasn't getting any younger and that he has a strong desire to take the knowledge he acquired and see his projects actually come to life, he made the switch and joined Tapani's construction team in the Tri-Cities Area. Since then, Craig has played a key role in timely procurement and project management assistance of Blaine Bellikka and Craig Schmitt on over ten large-scale projects. Craig brings passion, pride, and a deep sense of ownership and commonality to every project he contributes to.

### KEY PROJECT EXPERIENCE

- \$7.4M** EID FRP Pipeline Contract 3, East Irrigation District (Project Engineer)
- \$4.9M** Sienna Hills Phase 1 Pump station & Bermuad Road (Project Engineer)
- \$4.7M** EID Boring & Crossings Contract 1, East Irrigation District (Project Engineer)
- \$3.5M** PWRP Utility Extension, City of Pasco (Project Engineer)
- \$2.9M** UAS Phase IV Industrial Park, City of Pendleton (Project Engineer)
- \$1.6M** EID Steel Pipeline Contract 2, East Irrigation District (Project Engineer)

## 2. Self Performed Work

Tapani is one of the unique contractors that self-performs both civil and structural construction, giving any owner an advantage of flexibility by limiting the majority of the critical and time-sensitive scopes of work to the responsibility of one contractor, Tapani. By self-performing our own concrete work, vertical construction, and all civil / utility work we will: limit the overall scope cost, have greater control of the overall schedule, have greater flexibility to address any challenges that may arise with the limited five month construction schedule of the pump station and pipeline, and have greater confidence that quality construction was performed from the start.

Tapani's Self-Performed Work on the Ordinance Project	Contracted Work Expected on the Ordinance Project
<b>Division 03 - Concrete</b> 03 30 00 Cast-In-Place Concrete	<b>Division 13 - Irrigation Pumps and Motors</b> 13 82 00 Irrigation Pumps 13 82 01 Irrigation Pump Motors
<b>Division 31 - Earthwork</b> 31 23 33 Excavation, Trenching, Backfilling	<b>Division 22 - Plumbing</b> 22 15 13 General Service Compressed Air Piping
<b>Division 33 - Utilities</b> 33 05 24 Steel Pipe 33 05 36 FRP Pipe 33 14 11 Pipeline General Requirements	<b>Division 33 - Utilities</b> 33 05 07 Boring and Jacking
<b>Division 13 - Special Construction</b> PEMB Erection	<b>Division 26 Electrical</b> 26 18 39 RVSS- Medium Voltage Switch Gear and MCC 26 18 39 VFD- Medium Voltage Variable Frequency Drives

**IN-HOUSE RESOURCES** | Tapani also provides a variety of in-house resources that help mitigate project costs, including an equipment and metal fabrication shop, trucking business, material dumpsites and pits, multiple small tool shops, a large flagging/traffic control team, in house testing and inspection team, full-time erosion control specialist, and in-house nurses that work full time for Tapani's safety department. Tapani's owns a fleet of more than 350 pieces of equipment that is positioned to serve every self-performed scope of work. To ensure longevity and dependability of our equipment, we also have a team of highly qualified mechanics that are available 24 hours a day, seven days a week, to ensure equipment stays at its peak performance. Lastly, our equipment and fabrication shop frequently engineers and fabricates unique items or equipment that provide time or cost savings to the project. *A key example of this is when our team designed special trenching boxes for all of Tapani's WWSP projects installing 66" welded steel pipe through Sherwood, OR.*



lifespans and reducing long-term costs.

**TAPANI'S TRI-CITIES OFFICE** | Tapani Tri-Cities' office has the unique advantage of having full access and support all of the resources available at Tapani's headquarters, as well as a set of resources that are specific to the Eastern Washington and Eastern Oregon areas. **With 40 full time employees who live in the area, this office includes an equipment shop staffed by a full-time mechanic, a fleet of Tapani Trucking trucks based locally, and an established network of relationships with suppliers and subcontractors in the region.**

The presence of an equipment shop with a full-time mechanic is a significant advantage for our Tri-Cities office. It means that our team can maintain and repair equipment quickly and efficiently, minimizing downtime and maximizing productivity. Our mechanic also performs preventative maintenance on equipment, extending

The local Tapani Trucking trucks are another key resource for the Tri-Cities office. They enable our office to transport materials and equipment quickly and easily, without having to rely on external transportation providers. This enhances our ability to deliver projects on time and within budget.

The established network of relationships with local suppliers and subcontractors is a testament to the Tri-Cities office's commitment to building a strong local presence. With our strong network of local suppliers and subcontractors, our teams reduce lead times and ensure high-quality materials and services at a competitive price.

# 5.5 PROJECT APPROACH

## 1. Overall Approach

### DESIGN ASSIST, PROCUREMENT & COMMUNICATION THROUGHOUT THE PROJECT

	2023												2024				
	A	M	J	J	A	S	O	N	D	J	F	M	A	M			
<b>NOTICE OF INTENT TO AWARD</b>	■																
<b>PRE-CONSTRUCTION PHASE</b>	■																
<b>Pre-Construction Meeting</b>	■																
<b>Weekly Design Assist / Recommendations</b>	●	●	●	●	●	●	●	●	●	●	●	●	●	●	●	●	●
<b>Early Procurement of Materials</b>		■	■	■	■	■	■	■	■	■	■	■	■	■	■	■	■
1. Steel Pipe		■	■	■	■	■	■	■	■	■	■	■	■	■	■	■	■
2. FRP Pipe		■	■	■	■	■	■	■	■	■	■	■	■	■	■	■	■
3. Steel Materials (Callie's)		■	■	■	■	■	■	■	■	■	■	■	■	■	■	■	■
4. Precast Vaults		■	■	■	■	■	■	■	■	■	■	■	■	■	■	■	■
5. Building Shell		■	■	■	■	■	■	■	■	■	■	■	■	■	■	■	■
6. HVAC		■	■	■	■	■	■	■	■	■	■	■	■	■	■	■	■
7. Electrical Panels/Equipment		■	■	■	■	■	■	■	■	■	■	■	■	■	■	■	■
8. Electrical Radio Tower		■	■	■	■	■	■	■	■	■	■	■	■	■	■	■	■
9. Electrical Control / PLC		■	■	■	■	■	■	■	■	■	■	■	■	■	■	■	■

At the heart of Tapani’s project management approach is the belief that strong teams are essential for successful projects. To build and maintain a strong team, Tapani emphasizes mutual respect, clear communication, and trust. This process begins in the pre-construction phase with pre-planning, identifying potential challenges, and brainstorming innovative ideas with the owner and design team. By maintaining this partnership throughout the project, Tapani ensures that the project is set up for success from the very beginning.

**PRE-CONSTRUCTION MEETING/PROJECT KICK OFF.** Upon award of the contract, Shane MacArthur will promptly reach out to Umatilla County to arrange a project kick-off meeting. The meeting will involve Tapani’s team, Umatilla County, and IRZ, and will focus on reviewing the project’s key objectives. During the meeting, the team will assess the status of design scope completion schedules, lead times of owner-procured materials, and establish a priority submittal list- as approved submittals will be key in ensuring we can order materials on time. To ensure that the project stays on schedule, clear lines of communication and responsibilities will be reviewed, including our use of Project Sight as a collaborative design/management tool.

**WEEKLY DESIGN ASSIST / RECOMMENDATIONS.** Aaron Halling, Shane MacArthur, Blaine Bellikka, and Kurt Cichosz will all be involved weekly with design reviews and constructability recommendations. At this point, we recommend that weekly meetings be held over Microsoft Teams with in-person meetings as necessary.

**EARLY PROCUREMENT OF MATERIALS.** The largest risk we on this project is being delayed in approved submittals, and in turn being delayed in our early procurement of materials. With electrical materials at 4-6 month lead times, it is essential that all possible relating design scopes are completed as soon as possible and that submittals are approved quickly.

**COMMUNICATION MAINTAINED THROUGHOUT THE PROJECT.** Maintaining a partnership throughout the project will be made possible by setting up weekly progress meetings. Progress meetings will include Shane MacArthur and Kurt Cichosz, with other key team members involved as necessary. Progress meetings will cover the following topics:

- Project updates from the previous week
- Two-week schedule of task break-downs
- Project successes
- Project Challenges
- Any changes in site conditions/unforeseen conditions
- Safety of crews, site, and public
- Coordination and planning with other key stakeholders
- Testing & Inspections

# PHASE 1: PUMP STATION CONSTRUCTION

2023		2024				
N	D	J	F	M	A	M

PHASE 1: PUMP STATION CONSTRUCTION						
Site Grading / Staging Yards	■					
Underground Utilities: Air Lines, Adjust Pump Can, Install Manifold & Pipe to Surge Tank, Underground Electrical	■					
Concrete Foundation Pads	■					
Set Pumps & Motors & Remaining Above-Ground Mechanical	■					
PEMB	■					
Electrical, HVAC & Programming	■					
Air Tank & System	■					
Radio Towers	■					
Prep & Set Surge Tank	■					
Install Air Tank & Sytem	■					

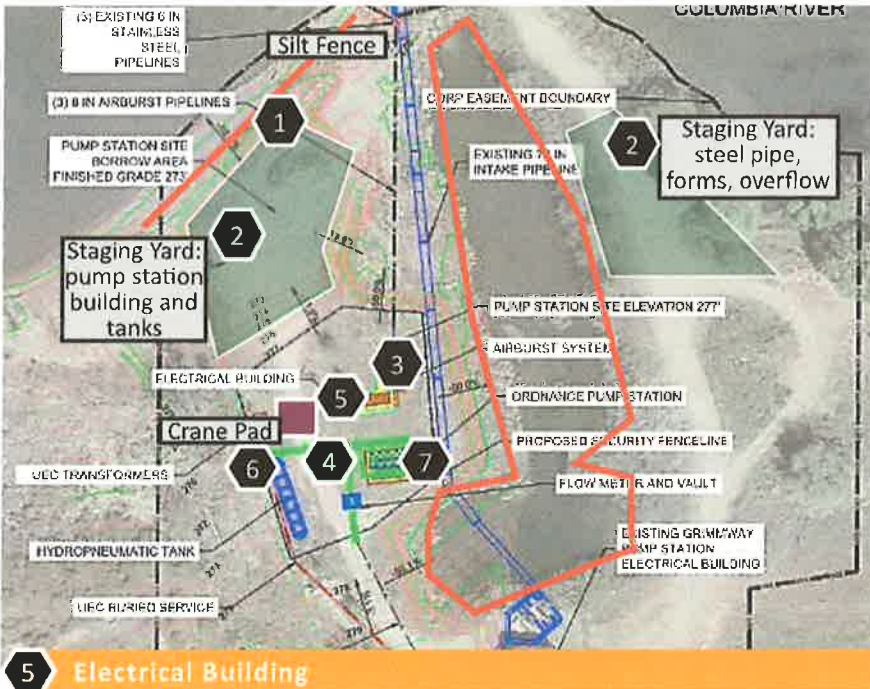

## 1 Grading/Earthwork Preparation

Crews will start construction at the Pump station site. Erosion Control Measures erosion control measures in place along any exposed bank and cut and fill to grade.

## 2 Staging Yards

Crews will prep two staging areas on either side of the pump station. The West staging yard will hold the pump station building and tanks. The East staging yard will hold pipe, forms, and overflow materials.

## 3 Underground Utility Work

1. Crews will connect to existing airlines (adjust height) with (3) 6" HDPE airburst pipelines and will stub at the edge of the future electrical building pad.

2. Crews will install the steel discharge piping and will stub at manifold (with cdf backfill) and run length connecting to surge tank, vault, and pump station. If flow meter and vault is there, it will also be installed at this time. The flow meter will be installed as soon as it arrives.

3. Crews will then excavate all electrical trenches and work with the electrical contractor to stub all electrical utilities to the edge of the future building pads, including the electrical for the UEC transformer.

## 4 Concrete Foundation Pads

Tapani's structural concrete crew will pour all of the concrete foundations: pump station pad, electrical building pad, surge tank pad/footings, and transformer pads.

## 5 Electrical Building

Tapani's crews will self-perform the PEMB structure. With the PEMB having a lead time of only 12 weeks, we expect the building package to be available once we are on site. After the concrete foundation is poured, crews will erect the building and rough in the electrical work and siding. With the main electrical equipment having the longest lead times (4-6 months), air equipment and remaining electrical will be constructed last.

## 6 Surge Tank

Working with NessCambell (who was our crane operator on DNR Paterson pipeline & pumpstation), a 275 ton crane will be used to lift and place the surge tank on its foundation. Tapani will submit a crane access and placement plan for approval during the preconstruction phase.

## 7 Pump Station

Crews will set the remaining pump station components: four discharge heads, fittings and valves, etc.

# PHASE 1: PIPELINE CONSTRUCTION

	2023		2024				
	N	D	J	F	M	A	M
<b>PIPELINE STA.0+00 - 163+55</b>	[Red bar]						
<b>FRP Pipeline: Sta.26+40 - Sta. 163+55</b>	[Black bar]						
<b>Williams Gas Line Crossing - 64" Casing</b>	[Black square]						
<b>Steel Pipeline: Sta.0+00 - 10+00</b>			[Black bar]				
<b>Trenchless Crossing under HWY 730</b>			[Black bar]				
<b>Steel Pipeline: Sta.11+00 - 21+50</b>				[Black square]			
<b>WEID Canal Crossing</b>				[Black bar]			
<b>Steel Pipeline: Sta.22+00 - 26+40</b>					[Black square]		

## 1 FRP Pipeline Sta.26+40 - 163+55

**1. SEQUENCE:** Due to the limited access into the pump station site, initial pipeline construction will begin at the Steel-to-FRP transition at Sta.26+40 and work South to the Depot Land tie-in to Phase 2. This sequencing plan allows us to stack the critical pump station construction with the pipeline construction without either of them hindering one another (starting with the steel at the pump station would create extremely limited access to the pump station and significantly slow productions to both crews.



Crews will kick off the project with a day of utility locates and will then spend approximately 12 days off loading the pipe sticks at the staging areas along the alignment. All topsoil along the alignment will be stripped, stockpiled, and covered for later restoration services. Crews will then work Southbound installing the pipe, fittings, drainline, ARV and delivery point utilizing shoring boxes stationed bell to bell and water trucks to wet material down to optimum moisture. Tapani will perform all of the pipe testing and inspections in-house. After the pipeline is completed, crews will go back down along the alignment and replace and restore the top two feet of topsoil.

**2. PIPE STAGING:** Blaine Bellikka has been in contact with Onyx/Grimmway to discuss pipe staging operations, determining that any land outside of their crop circles can be used as temporary staging yards. Our plan is to offload and stage sections of pipe at these “in-between” parcels, and then drive each pipe stick down to it’s location individually using a Stinger operation. *This operation is detailed more in Section 5.10 Additional Information.*

**3. WATER SOURCE:** Our team has identified two sources of water.

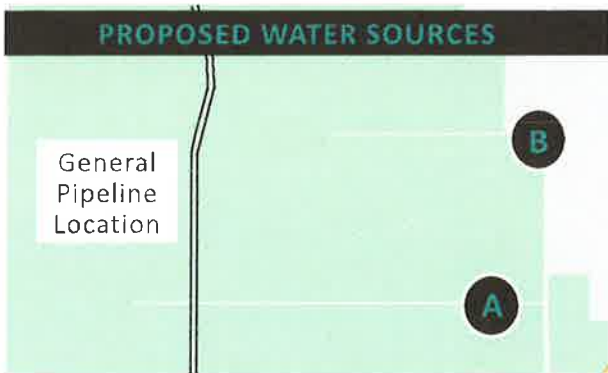

- A** The first has been coordinated with Onyx/Grimmway. Their water source is located off of Powerline Road and Ptl lane, approximately 1.4 miles from Phase 1 & 2 FRP portions of the pipe alignment. Our plan is to use Grimmways source as the primary source of water, with the City’s hydrant as a back-up plan.
- B** The second is the City of Umatilla’s fire hydrant located at the intersection of County road 1225 and County road 1226.

Bonneville Power Crossing	Williams Gas Line Crossing & Casing + Other Utility Crossings	Restoration Efforts
Crews will take extra precautions while working under the BPA Transmissions line. Green Warning cones will be placed across the alignment as a warning.	Tapani will install 100 lf of 64" steel casing through open trench methods under the Williams Gas Line crossing. There are also many other gas, irrigation, and power crossings that will be navigated with extra precaution.	With this section of the alignment through crop circles, extra care will be taken to restore the ground’s topsoil back to original conditions. Tapani will stockpile and wet the stripped topsoil and place back on top of the alignment.



## 2 Trenchless Crossing - HWY 730

Work on the trenchless crossing will be split into three phases:

**1. Construct the Bore Pit.** Working in the median between Southshore Drive and HWY 730, crews will erect a safety fence around the work zone with safety signage indicating an open pit. Tapani will excavate the pit dimensions as needed and will create a temporary berm with the excavated material between the pit and HWY 730, which will serve as a safety barrier from the live traffic. The bore pit will be shored

with standard Shoring boxes and steel sheets. Any excess material will be hauled to the staging and screening yard shown above. Acceptable material will be saved as pipe bedding and backfill and unsuitable material will be hauled offsite.

**2. Construct the Receiving Pit:** Located on the South side of HWY 730, Tapani will construct the receiving pit in the same manner as the bore pit. Adjacent to our easement here is a residential access road. With such a limited easement at this location, potential use of the driveway as a turn-around ample pre-planning and communication with the homeowner's will be critical to ensuring safe movement of equipment and operations through their areas and our limited easement.

**3. Perform Jack and Bore:** If the bore subcontractor encounters a boulder during the boring operations, they will have equipment to complete the bore with hand tools.

## 3 Steel Pipeline Sta.0+00 - 10+00

**1.** Due to the constricted access into the pump station site, construction of the steel pipeline from the pump station (0+00) to the bore pit (10+00) will start after the majority of the pump station grading, utilities, concrete, and structural work has been completed so as to minimize disruptions to the pump station schedule.

**2.** Starting at the pump station, crews will work Southbound to install the 48" pipeline. Pipe materials and

screening operations will be set up adjacent to the alignment (shown on the map above) utilizing Onyx/ Grimmway's offered staging yard.

**3.** Crews will temporarily close a section of Southshore Drive for for the open-trench crossing. With access out on either end, this should not cause any disruptions to homeowners along the street.

## 4 Steel Pipeline Sta.11+00 - 21+00

Located on the south side of HWY 730 and tying into the receiving end of the bore casing, this section of pipeline will be installed moving southbound down a very narrow Onyx easement. With only a private residential access road running along the easment, coordinating material haul-offs for screened materials could prove challenging. In order to ensure the safe access of equipment on and off of HWY 730, our goal would be to get owner permissions for a turn-around area on their driveway. If not, a one-way temporary haul road will be constructed that will tie into the WEID canal easement and exit through Kurz Ln.

## 5 WEID Canal Crossing

As a historical structure, protection of the WEID canal will be our highest priority. To protect it from damage, crews will place foam pads over the top of all areas within the construction zone and top with a plastic covering. For careful demolition of the existing wall, crews will sawcut and remove small pieces at a time in order to prevent large chunks of falling debris. A wall demolition plan will be submitted prior to commencement of work. The pipe crew will set a temporary brace wall and place the pipe, and a concrete crew will follow with the construction of the three new walls, securing the pipe in place.

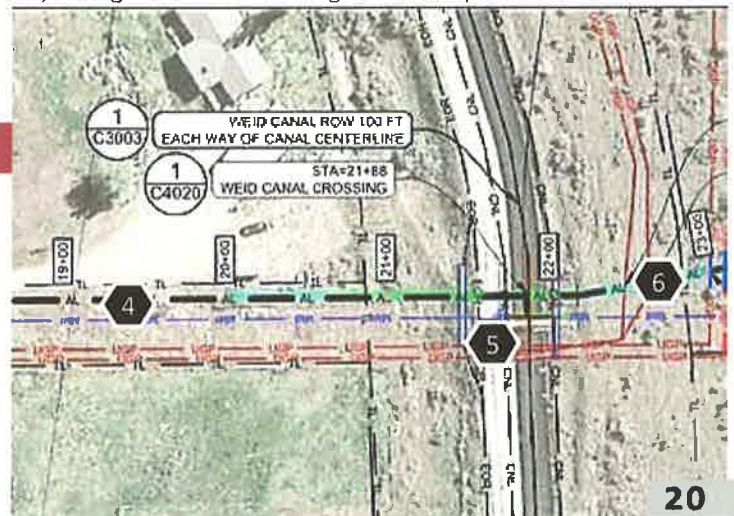

**5 Steel Pipeline: Sta. 22+00 - 26+40**

The remaining portion of the steel pipeline will be accessed from the south side of the project coming in west from County Rd 1226. This section of the pipeline is in a very limited easement, on a very steep incline and encounters four underground power line crossings. Crews will perform potholing to verify depths of each crossing and will build a temporary, one-lane haul road down this hill to provide safe access for crews and haul off of material for screening. Extending up from the WEID canal crossing, pipe sticks will be brought down and placed one at a time using a stinger attachment. Water trucks will spray the area from the top of the hill to maintain dust control and provide adequate compaction.



**PHASE 2: PIPELINE CONSTRUCTION**

	2023		2024				
	N	D	J	F	M	A	M
<b>CONSTRUCTION PHASE 2: FRP in Depot Land</b>			[Gantt bar spanning J, F, M, A, M]				
<b>Stage FRP from Laydown Area</b>			■				
<b>Strip Topsoil and Replace</b>			■				
<b>Install FRP Mainline &amp; Fittings - Crew 1</b>			■■■■				
<b>Install FRP Mainline &amp; Fittings - Crew 2</b>			■■■■				
<b>Install Drainline, ARV and Delivery Point</b>					■		
<b>Testing of FRP</b>						■	
<b>Radio Tower Install &amp; Electrical #3</b>					■		

Construction of Phase 2, which includes all of the FRP pipeline in Depot land, is a pretty straight forward section of work.

**#1 Access:** The only access point into the Depot property is at a gate located at the south end of the property, which will be easily accessed as it is right off of I-82. Crews will have to go through the Depot check in in order to access the project site.

**#2. Prepping the Alignment:** Our team noticed during our preliminary site investigation that there was a significant amount of extremely dry brush along the alignment. To prevent any fire hazards, we will disc and till the entire alignment through the Depot property.

**#3. Staging Materials:** Protected within the Depot gates, we will string out all of the the pipes along the alignment as our methods of staging. We see this as an advantage to both production rates, as well as the pipe acting as a natural barrier to strong SE winds.



## 2. Significant Proposed Modifications

PROPOSED MODIFICATIONS	IMPACT
All valves and assemblies along the alignment are presently shown to be located in concrete access vaults. Our proposed modification would be to replace the concrete vaults with vertical sections of CMP pipe topped with in-house designed and fabricated lids and insulated with spray foam. This method was utilized on Tapani's East Irrigation District projects.	Utilizing this method would provide an approximate 50% savings to this scope of work and would also provide a schedule acceleration as the proposed modification is significantly easier to install.
After performing early exploration test pits pre proposal submittal, we have deemed that the native material from station 26+40 to station 150+00 will meet backfill requirements and not require screening.	Based on our explorations, the bid item for screening material from station 26+40 to Station 150+00 will not be necessary, resulting in a <b>savings to the Owner of up to \$272,800.00</b>

## 3. Approach to Management, Quality Assurance, & Cost Controls

**APPROACH TO MANAGEMENT** | With a top down approach, Tapani manages our projects within the frame of mind that **Strong Teams lead to Successful Projects**. As our founding principal, we recognize that a strong team is built and maintained through professionalism, competence, good character, passion, and unity stemming from mutual respect of every team member. A successful project is executed when a strong team delivers the project safely, with quality, strategy, commitment, and develops long term relationships with the owner's, engineers, subcontractors, suppliers, and communities our work impacts. With the dynamic phases/scopes of work on the Ordnance project, our key to successful management comes from clearly defining each member's roles and responsibilities, ensuring that no large or small details fall through the cracks.

### TOD TAPANI | Project Principal

- Owner contact for Umatilla County
- Assurance on resource deliverables
- Internal support of management team on project direction, schedule, financials, overcoming challenges, and safety.

### ELLE BUCHO | Safety & Erosion Control

- Erosion and sediment control plan, implementation, and adherence
- Job hazard analysis plan
- Task-specific safety plans
- Jobsite safety walks and corrective action plans
- Communicating safety expectations to subcontractors and suppliers

### BLAINE BELLIKKA | Regional Manager

- Key contact and relationship with IRZ
- Planning and scheduling assist / input for Shane MacArthur
- Overseeing & ensuring general success of project

### AARON HALLING | Desing Assist / Recommendations

- Utilize engineering, project management, estimating, and DBIA background to review remaining designs and provide recommendations

### CRAIG SCHMITT | Procurement / PE

- Work with suppliers to understand and navigate lead times, procure materials, and track them upon arrival

### SHANE MACARTHUR | Project Manager

- Main point of contact for Umatilla County
- Manage meetings, contract details, and lead Pre-Construction planning, design reviews and ordering of materials.
- Manage, verify and lead the project team to ensure tasks are completed accurately and on-time with the best tracking and storage tools
- Manage submittals, RFI's and construction documents
- Review and approve project changes affecting scope, cost, quality, or time.

### ZANE SHAUT | Structural Project Manager

- Manage crews, resources, planning, scheduling, and construction of all structural components of the project
- Work with Shane MacArthur on all structural submittals, RFI's, and material procurement

### KURT CICHOSZ | Project Superintendent

- Manage crews, subs. and suppliers daily
- Execute the work plan in adherence to specifications while ensuring a culture of safety
- Coordinate delivery & staging of resources and materials
- Coordinate internal traffic control & sequencing
- Provide two-week construction schedule plan updates throughout the entire project
- Manage security measures during/after work hours
- Quality assurance of materials and work
- Provide two-year maintenance repairs

**APPROACH TO QUALITY ASSURANCE & COST CONTROLS** | Umatilla County is already at an advantage by using the RFP method of contract, which allows a partnership with a contractor to be based off of more than just cost, but also reputation, values, and history of workmanship. Based on Tapani's positive and successful experiences working with both IRZ and Umatilla County, we hope that our actions speak for the fact that our team approaches every project with the mutual success of the entire project team in mind. This means that we gladly aid in looking for ways to improve the quality, practicality, constructibility, and longevity of our work while constantly balancing cost controls against the overarching project goals. At the end of the day, we want to build a project we are proud of and cultivate long-term relationships - which means delivering quality services and realistic bids.

**Our first advantage** in quality assurance and cost control lies in our ability to self-perform the majority of the work scopes. First, we see the implementation of our team throughout the rest of the design as a huge opportunity to pinpoint constructibility issues and work with your team to provide innovative solutions up front - before they are a problem in the field. Since our team will be self-performing the civil, utility, concrete, and structural scopes of work, much of the project's quality assurance and cost control will be in the direct responsibility of our team. This is great, as we already know that our standards for adherence to specifications are high and that our teams are flexible when any challenges arise.

**Our second advantage** in quality assurance and cost control is our choice to partner with reputable subcontractors that build quality work and show up with the same values we do - honesty, integrity, hard work, and professionalism. With the boring operation, electrical, and welding scopes all critical scopes that own high risks if challenges arise, having humble experts on this project was key to our decision making. Partnering with Prairie Electric (who has a long and successful history working with our team) Callies Welding, and Gonzales Boring and Tunneling, gives us confidence that this work will get done with quality workmanship and within budget.

**Our third advantage** is our Superintendent, Kurt Cichosz, who brings an exceptional attention to detail and an unmatched passion for innovation in the field. As construction of the project commences, Kurt will coordinate and inspect all material deliveries, oversee daily construction tasks, coordinate testing and inspections, and meet with every subcontractor to review their task plan prior to commencement of their scope. If any unforeseen challenges arise, Kurt will coordinate with Shane MacArthur and Umatilla County to determine the best course of action forward. Progress will be documented and reviewed in a weekly meeting with Shane, Umatilla County, and IRZ, along with two-week-look-ahead schedule breakdowns.

Lastly, Tapani will provide both in-house testing and testing and inspection services for the following items: **steel reinforcement placement, steel reinforcement welding, headed bolts and studs, verification of use of required design mixture, concrete placement including conveying and depositing, curing procedures and maintenance of curing temperature, and verification of concrete strength prior to removal of shoring/bracing and forms from beams and slabs.**

#### 4. Approach to Bidding Out the Project

Blaine Bellikka, Craig Schmitt, and Aaron Halling have conducted a thorough assessment of the Ordnance site, reviewed project documents, collaborated on the optimal project approach, and communicated with key subcontractors and suppliers to identify the key factors that will affect procurement, price, and schedule for the Ordnance project. With timely completion of the pump station and pipeline critical to springtime industrial and agricultural productions, we recognized that project success will rely on more than just low price. With this in mind, evaluating reputation, company location, history of successful experience, and collaborative capabilities was key to determining who was invited to bid on this project.

After analysis of cost, reputation, safety history and prior working experience, Tapani has chosen the following subcontractors to partner with on this endeavor. With their expertise, local experience, and familiarity with both Tapani's team and IRZ, we are confident that these partnerships will provide the best overall experience, on-time delivery, and quality of work.

WELDING	JACK & BORE	ELECTRICAL	HVAC	FENCE
Callies Welding & Fabrication LLC	Gonzales Boring & Tunneling	Prairie Electric	Columbia Allied Services	Frontier Fence, Inc.
				

## 5. Approach to Site Access Constraints

Tapani's team has met on-site multiple times to evaluate the pipeline easements and their potential impacts on construction. Our results are documented in the table below.

Phase 1- steel pipeline, contains the most challenging easement conditions. Our approach to building successfully within these limits starts with the creation of an access and traffic control plan. Many of these easements will only have capacity for one-way or one-machine-at-a-time traffic flows. Identifying these pinch points early on and integrating their impacts into our schedule will help us mitigate safety risks, maintain productions, and successfully coordinate material deliveries and subcontractor scopes.

A key example of this is the narrow easement from sta.0+00-10+00, where the steel pipeline ties into the new pump station. Since installation will take up the entire easement and severely limit access to the pump station site, our team has scheduled installation of this section last in order to maximize delivery times and construction of the pump station.

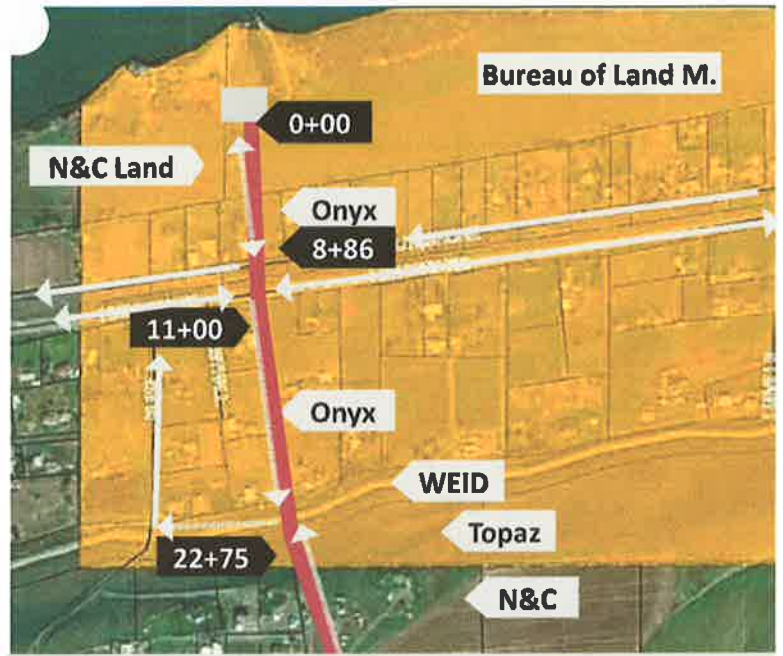



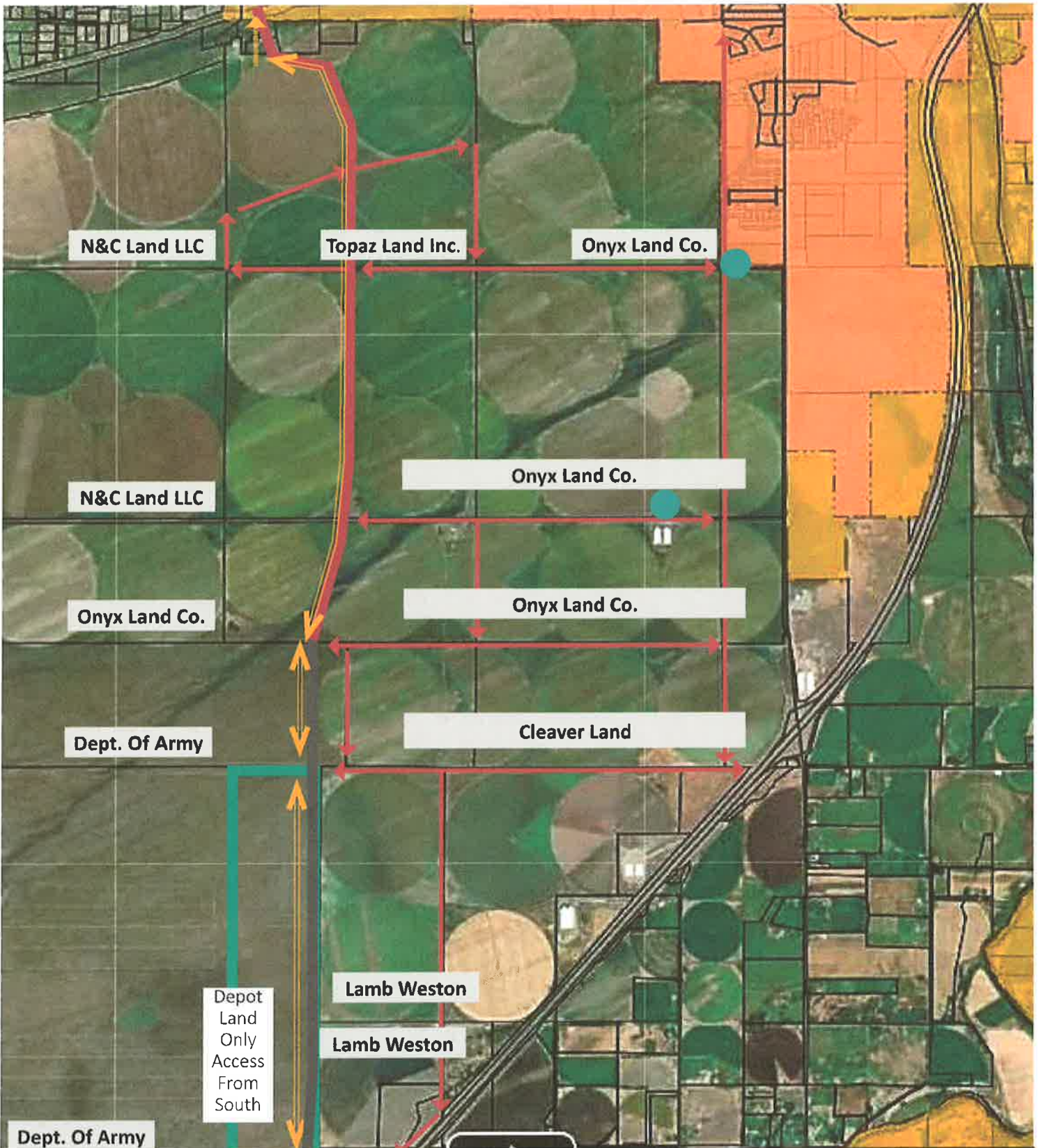

**PHASE 1: STEEL PIPELINE ACCESS PLAN**

### TAPANI'S SITE WALK / ACCESS EVALUATIONS

Start	End	LF	Pipe	Type	Key Stations	Easement
0+00	0	0	48"	Steel	Pump station	Large
0+00	5+50	550	48"	Steel	CORP Easement	Tight
5+50	8+86	336	48"	Steel	Onyx/Grimmway Easement	Large with using their lay down yard
8+86	9+26	40	48"	Steel	Southshore Drive Open Cut Crossing	Tight
9+26	9+75	49	48"	Steel	Southshore Drive to 730 Bore	Tight
9+75	11+00	125	48"	Steel	730 58" Bore	Tight
11+00	20+75	975	48"	Steel	730 HWY to Canal	Tight
20+75	22+75	200	48"	Steel	Canal Crossing (WEID Canal ) Demo and Concrete Work	Tight and Steep
22+75	26+40	365	48"	Steel	Install Steel up Hill	Large Steep
26+40	26+40	0	1300mm Bar 20	N/A	Pipe Material Change From Steel to FRP	Field
26+40	63+00	3660	1300mm Bar 20	FRP	Digging next to access road poor condition	Field
63+00	66+00	300	1300mm Bar 20	FRP	BPA Overhead Crossing	Field
68+40	69+40	100	1300mm Bar 20	FRP	William Gas Crossing 64" Casing	Field
84+03	84+53	50	1300mm Bar 20	FRP	County Rd Open Cut 1226 #	Road
137+14	137+64	50	1300mm Bar 20	FRP	County Rd Open Cut	Road
163+55	163+55	0	1300mm Bar 20	FRP	End of Phase 1	Field
190+00	190+00	0	1300mm Bar 20	FRP	Start of Depot Property- Fence Crossing/Access from South	Army Depot 60' Easement Between Fence and Road
190+00	196+22	622	1300mm Bar 20	FRP	Pipe Change	Army Depot 60' Easement
318+00	318+60	60	1100mm Bar 10	FRP	Road Crossing Open Cut & Pave Back	Army Depot 60' Easement
335+25	335+75	50	1100mm Bar 10	FRP	Road Crossing Open Cut & Pave Back	Army Depot 60' Easement
335+75	336+00	25	1100mm Bar 10	FRP	End of Phase 2- Recharge Basin	Army Depot 60' Easement

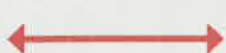









**PHASE 1 FRP & PHASE 2 FRP ACCESS PLAN**

-  Pre-Existing Access: One-Way Traffic
-  Pre-Existing Access: 2-Way Traffic
-  Fenced In Depot Property: Pipeline along 60' Easement from Fence to road.
-  Pipe-Alignment Haul Road: Limited Access/Easement
-  Pipe-Alignment Haul Road: Wide Access

## 6. Approach to Meeting Pipe Backfill Requirements

Our approach to meeting the pipe backfill requirements starts with understanding the requirements in relation to actual site conditions. In pursuit of providing a realistic idea of productions and cost, our team recently performed some exploratory work along the alignment by potholing 11 different locations. Based on our results (shown in the table below) and the following specifications, we have determined the following plan of action:

#	DEPTH	FINDINGS	PICTURE
<b>#1 &amp; #4 were not dug due to safety &amp; utility concerns</b>			
#2	11'	1' = topsoil 2'-11' = clean sand	
#3	10'	2' = topsoil 2'-10' = clean sand	
#5	10.5'	2' = topsoil 2'-10.5' = clean sand	
#6	9'	2' = topsoil 2'-9' = clean sand	
#7	11.5'	2' = topsoil 2'-11.5' = clean fine sand	
#8	11.5'	2' = topsoil 2'- 11.5' = coarse sand	
#9	12'	2' = topsoil 2' - 5' = sand 5' - 12' = course sand	
#10	12.5'	2' = topsoil 2' - 6' = sand 6' - 12.5' = 3/4" to 6" round rock	
#11	12'	2' = topsoil 2' - 12' = 1/2" to 2' rock/ boulders	

### 1. According to specifications, backfill material must meet the following requirements:

Steel Pipe: Max 1/2"  
FRP Pipe: Max 1"  
PVC < 12" OD: Max 3/4"  
PVC > 12" OD: Max 1"

**2. From the Pump Station to 26+00 = Screened Material.** In-line with the geotechnical report recommendations, all trench material will be exported to a screening site located on the East side of the pump station entrance, within the Onyx property. Rejected material will be disposed of offsite and suitable material will be hauled back to the alignment as fill.

### 3. From 26+00 to 150+00 = Native Backfill.

Tapani's potholes 2-9 found fine sand all the way down to depths of 11 feet. Although geotechnical recommendations are for screened material, we see a significant cost saving opportunity here by using the suitable native material as backfill. Pipe along this alignment section will be backfilled with native material.

### 4. From 150+00 to 336+00 = Screened Material.

Potholes 10- 11 found 1/2" - 1' size rocks/boulders 4-6 feet below surface. These findings support geotech findings that the alignment in Phase 2 will need screened material to meet backfill requirements. Tapani will set up a screening operation along the pipeline or within an approved staging area.

### 5. Special Requirements for Farmland Disturbance.

All of Phase 1 FRP, from Sta.31+00 to Sta.163+00, runs through N&C, Topaz, Onyx and Cleaver actively used farmland. Minimal disruptions of soil conditions is critical to the success of their operations. For this section of alignment, Tapani will strip and stockpile the top two feet of strippings and replace them at the top of the pipe backfill.

### 6. Meeting Compaction and Moisture

**Requirements.** Material will be conditioned in place using water trucks running along the alignment. We are expecting areas within the irrigated farmland to be close to prime moisture, requiring minimal involvement. Compaction will be accomplished using an excavator pinwheel attachment and rollers.

## 7. Approach to Site Safety & Security

Prior to commencement of work, Shane, Zane, Kurt, and Elle will meet on-site to evaluate safety hazards and create

a detailed site-specific safety plan that will be adhered to throughout construction. This plan will be reviewed by Umatilla County for approval, and by all construction teams and subcontractors prior to working on site. On a daily basis, Kurt will lead morning safety meetings that will integrate preventative safety practices such as stretch-and-flex routines with the crews and review of daily task-specific safety plans. The map and list below are the key areas



### 1 Pump station staging yard with high-value equipment

Security fencing will completely enclose all staging areas/ pump station site with sole access through a locked gate. Video surveillance and security lights will be placed at the entrance.

### 2 Limited access into/out of pump station site

Construction access off of Southshore Drive is limited to single lane access, with limited turn-around space within the pump station site. Diligent radio communication with incoming/outbound vehicles will be key for avoiding any accidents.

### 3 Utility Crossings sta.6+00-11+00 / Southshore Drive Crossing

Be diligent in potholing and hand-digging of 2 irrigation crossings, 2 gas crossings, and a fiber crossing (near bore pit). A temporary closure of the open-cut section of Southshore Drive will temporary limit access to the site.

### 4 Highway 730 Trenchless Crossing

Safety around the bore pits will be critical in protecting both workers and vehicular traffic. Tapani will place fencing and signage around the open pits and create a protective dirt berm between the highway and pit using trench spoils. Preventing any settling under the Highway 730 is also critical to success.

### 5 Historic WEID Canal Crossing w/Limited Access on Both Sides

Easement widths on both the north and south access points to the canal are very narrow, and the south entrance also fairly steep. On the north side, crews will travel one direction to deliver, install, and transport out unsuitable material, accessing the canal through the pipeline easement off of HWY 730. On the south access point, crews will be limited to transporting one pipe stick at a time down the slope. A more in-depth safety analysis of work along this slope needs to be done once contract is awarded.

### 6 Work Under the BPA Transmission Lines

To enhance the safety of our employees and subcontractors working near the BPA power line, Tapani will be placing green cones on both sides of the roadway leading up to the crossing This will help ensure that everyone is made aware of the presence of the power line before moving under it, particularly when equipment is being moved under. To minimize the risk of accidents, we have set a maximum height limit of 14 feet above ground for all equipment passing under the power lines.

### 7 Williams Gas Line Crossing

Crews will need to hand-dig around the Williams Gas Line crossing to ensure no damage is done while installing the 64" steel casing, 1300 mm carrier, end seals and casing spacers.

### 8 Risk of Fire

Our team identified a significant amount of dried brush along the Phase 2 alignment that could be cause for fire concern. Our approach will be to disc and till all of the brush between the road and the Depot fence, and then string all of the pipe sticks down the alignment to block incoming SW winds.

## 8. Long Lead Items & Potential Impacts

Tapani's approach to mitigating the risks of long lead items is to identify them early on and start the approval/ordering process as soon as possible. With forward planning, we don't see many of these lead times posing a huge risk unless there are major changes in design.

LEAD TIMES FOR CRITICAL COMPONENTS			
Material	Supplier	ETA	Impact to Project
48" Steel from Northwest Pipe	Owner	10.30.23	None
Callies Material (Includes Casing)	Owner	9.29.23	None
FRP Pipe	Owner	11.1.23	None
Precast	Supplier	5 months after approved drawings	Finished drawings are critical to schedule. Preferably complete by July.
Steel Flanges	Callies Welding	3 weeks after approval	None
PEMB Building Shell	Supplier	12 weeks after approved drawings	Finished drawings are critical to schedule. Preferably complete by September.
HVAC	HVAC Sub	10 weeks after approved submittals	None
Electrical Panels/Equipment	Electrical Sub	6 months after approval	Approved submittals + ordering is critical to schedule. Submittals need approved by May.
Electrical Radio Towers	Electrical Sub	4 months after approval	Approved submittals + ordering is critical to schedule. Submittals need approved by May.
Electrical Controls/PLC	Electrical Sub	5-6 months after approval	Approved submittals + ordering is critical to schedule. Submittals need approved by May.
Electrical MDP-B	Electrical Sub	38 Weeks	Need to find a temporary solution

## 9. Approach to Erosion Controls & Stormwater Management

Tapani's approach to erosion control and storm water management is to leave the impacted environment better than we found it; **our goal is to protect the ecological life in our streams and rivers by diligently adhering to State standards and proactively determining site contamination risks and best practice solutions.** This means determining what products will work best for each unique project, diligently managing water silt content, maintaining clean sites, and doing consistent quality control checks throughout construction.

**Stormwater:** With the climate in Eastern Oregon consistently dry- and with sandy and rocky soils of the Umatilla Basin which drain extremely well, there is a very low risk of encountering run-off on this project. Silt fence will still be placed along the Columbia River Bank at the pump station site to ensure no contamination of the river from construction activities occurs.

**Dust Control:** Managing dust control will play a much larger role in our daily erosion control tasks. With water sources located less than 2 miles from site, water trucks will be running daily

**Track Out:** Track out is not a concern as the access roads to the pipe alignments are long.

# 5.6 WARRANTY REPAIR APPROACH

## 1. Warranty Repair Commitment

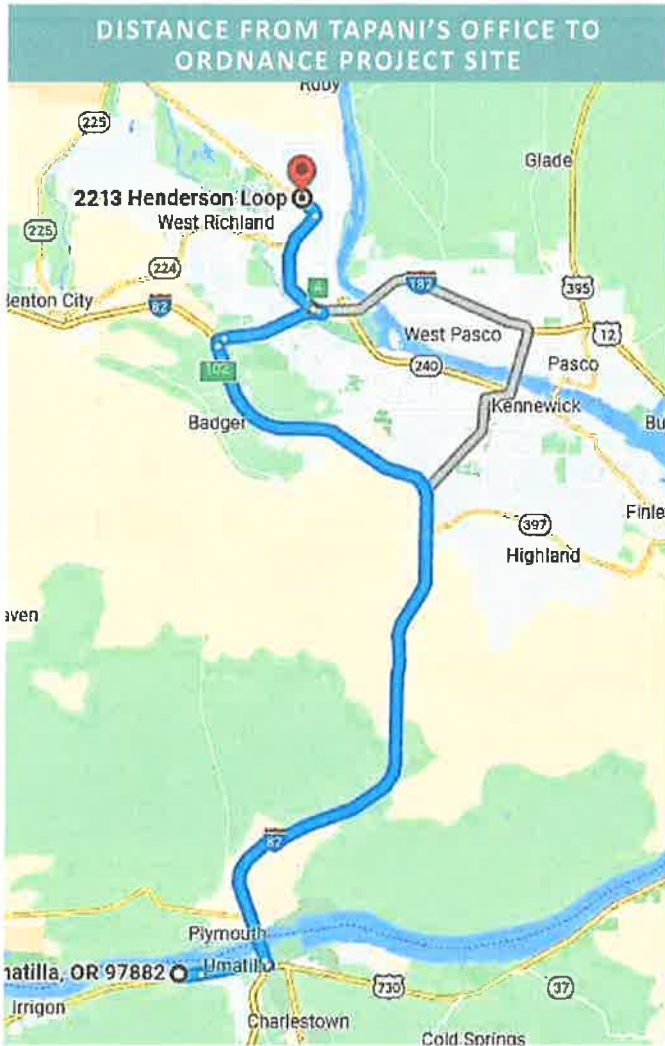

Tapani has a proven track record of responding swiftly and effectively to unexpected situations. Whether it's emergency pipeline repairs, dam restorations, or snow plowing, we recognize the critical importance of being there for our community and clients when they need us the most. Our commitment is to take immediate action, no matter the scale or complexity of the emergency, and worry about the details later. We understand that our clients rely on us to keep their operations running smoothly, and we are dedicated to delivering the highest quality service in any circumstances.

With our Tri-Cities office located 45 minutes from the project site, we have the resources and connections to respond promptly during the warranty period. Kurt Cichosz (Superintendent), Blaine Bellikka (Regional Manager/Regional Manager), and Kyle Callie (Callies Welding), are all committed to taking emergency calls and organizing a response team accordingly.

### Emergency contacts can be reached as follows

1. Kurt Cichosz, Superintendent: 360-907-8665
2. Dave Barela, General Superintendent: 360-907-8656
3. Blaine Bellikka, Regional Manager: 509-530-8065
4. Kyle Callies, Callies Welding: 509-392-2880
5. Tod Tapani: 360-907-8627
6. Tapani's Tri-Cities Office: 509-590-1184

### Emergency Equipment Available

- Low Boy
- Loaders
- CAT Excavators (CAT 336 - CAT 312)
- Pre-Assembled Prep Boxes
- Shoring
- Pumps

## 2. Repair Services Outside of Warranty Period

Tapani is dedicated to delivering prompt and reliable service to all projects, regardless of their contractual status. At the end of the day, the key purpose of this pipeline is to keep farming and industrial operations going. We understand that any malfunction or delay in the pump station or irrigation line could have serious consequences on the crops, industrial operations, and ultimately real people working to do their best. That's why we prioritize resolving issues as soon as possible and trust that any necessary adjustments or settlements can be addressed afterwards. Our commitment is to keep your operations running smoothly and efficiently, so you can focus on what matters most.

### KEY EXAMPLES OF TAPANI'S HISTORY WITH EMERGENCY REPAIRS

Year	Project Name	Owner	Location
<b>REFERENCES</b>			
Agri Northwest: Steven Madsen, 509-948-5375 Cody Neddo (Irrigation Manager) 509-366-0970 Clark Regional Wastewater District: (503) 880-5318			
2022	Pounder Road Repairs	Multnomah County	Multnomah County, OR
2022	Great Western Malting Concrete Repairs	Great Western	Clark County, WA
2021	Echo Pipeline- Pipe Fixes	Agri Northwest	Umatilla County, OR
2021	Dale Haagen Emergency- Building 5400	Dale Haagen	Clark County, WA



2021	Salmon Creek- Concrete Repair at Existing Structure	Clark County Public Works	Clark County, WA
2021	Whipple Creek Place Stormwater Facility Repair	Clark County Public Works	Clark County, WA
2021	Louden Road Emergency Repair	Mutnomah County	Multnomah County, OR
2020	Lewisville Dam Repair	Cadman Materials	Clark County, WA
2020	Dalles Commercial Dock Repair	KPFF Consulting	Wasco County, OR
2020	Kelso Sewer Emergency Repair	City of Kelso	Cowlitz County, WA
2020	Lift Station #6 Emergency Repair	City of Woodland	Cowlitz County, WA
2020	Emergency 509 N Horns Corner Drive	Clark Regional Wastewater District	Clark County, WA
2020	Emergency 518 N Horns Corner Drive	Clark Regional Wastewater District	Clark County, WA
2020	Discovery High School Emergency Repairs	Camas School District	Clark County, WA
2019	Emergency Sewer Lateral Repair 212 NE 117th Street	Clark Regional Wastewater District	Clark County, WA
2019	PLS Emergency Waterline Repair	Pacific Lumber	Cowlitz County, WA
2016	Bethany Creek Ph.1 Waterfall Repair	Polygon Northwest	Washington County, OR
2016	Emergency Landslide Remediation	City of Portland	Multnomah County, OR
2015	University Emergency	Romano Properties	Clark County, WA
2015	Hurley Development Sewer Emergency	Ryan Hurley	Clark County, WA
2015	Emergency Erosion Control Riverview	City of Riverview	Clark County, WA
2014	Oregon City Auto Waterline Repair	Monolith	Clackamas County, OR
2014	Hood River Slide Repair	ODOT	Hood River County, OR
2014	Emergency Courthouse Waterline Repair	Klickitat County	Klickitat County, WA
2014	Grand Mound Sewer Repair	Great Wolf Lodge	Thurston County, WA
2014	BPA Emergency Waterline Fix	Bonneville Power Administration	Clark County, WA
2013	SR 501/0.6 Miles West of Smythe Road Slide Repair	WSDOT	Clark County, WA

# 5.7 PROJECT SCHEDULE

**CREW 1: Struct. Concrete**

- 1 Foreman
- 2 Concrete Car-penters
- 1 Laborer

10K Forklift

**CREW 2: Steel Erection**

- 1 Foreman
- 3 Ironworkers

10K Forklift  
(3) Manlifts

**CREW 3: Mecht/Misc.**

- 1 Foreman
- 1 Operator
- 1 Laborer

336 CAT Excavator  
312 CAT Excavator  
624 JD Loader

**CREW 4: Grade**

- 1 Foreman
- 2 Operators
- 1 Laborers

312 CAT Excavator  
850 Dozer  
Roller

Water Truck

**CREW 5: Pipe**

- 1 Foreman
- 6 Operators
- 1 Pipelayer
- 1 Laborer

320, 349, 374 CAT Excavator  
850 Dozer  
624 JD Loader

Water Truck

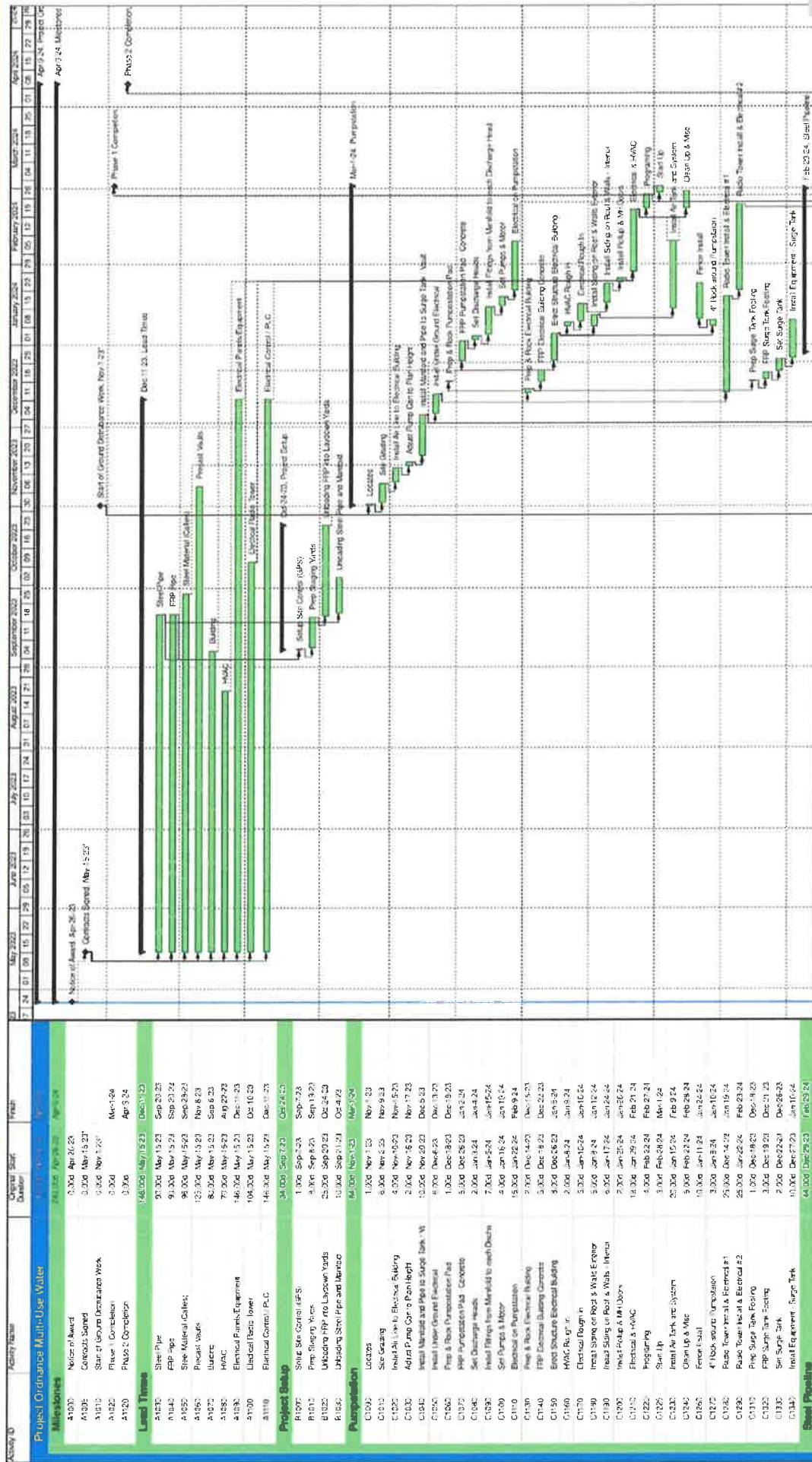



Activity ID	Activity Name	Original Start	Original Stop	Percent
D1000	Stage Steel from Laydown Area	5.000	Dec-29-23	Jan-05-24
D1005	Process Bedding and Backfill	20.000	Dec-29-23	Jan-06-24
D1010	Install Steel from Vault to Steel Pit	10.000	Dec-29-23	Jan-12-24
D1015	Temp Piping Substation Done	1.000	Jan-15-24	Jan-15-24
D1020	Install Steel from Retaining Pit to Canal	7.000	Jan-16-24	Jan-20-24
D1040	Remove Existing Diverter	1.000	Jan-25-24	Jan-25-24
D1050	Pave Substation Drive (Washman)	2.000	Feb-01-24	Feb-29-24
D1060	Install Steel to ST 730-A-0	7.000	Feb-05-24	Feb-14-24
D1070	Install Coating on Steel Joints	6.000	Feb-15-24	Feb-22-24
D1080	Test Steel Pipe Line	3.000	Feb-23-24	Feb-27-24
E1000	Locates	1.000	Dec-28-23	Dec-28-23
E1010	Dig Bore Pit	3.000	Dec-28-23	Dec-28-23
E1020	Jack & Bolt Casing	10.000	Dec-28-23	Dec-28-23
E1030	Install Center Pipe	2.000	Dec-28-23	Dec-28-23
E1040	Connection to Steel Pipe	2.000	Dec-29-23	Jan-02-24
E1050	Crew #1 Casing and	1.000	Jan-03-24	Jan-03-24
E1060	Borehole and Restore	2.000	Jan-04-24	Jan-05-24
F1000	Canal Crossing	20.000	Jan-16-24	Feb-27-24
F1010	Canal Casing Plan	5.000	Jan-16-24	Jan-24-24
F1010	Initial Protection in Canal	2.000	Jan-25-24	Jan-25-24
F1020	Dredge Existing Wall	3.000	Jan-29-24	Jan-31-24
F1030	Install New Steel Pipe	1.000	Feb-01-24	Feb-05-24
F1040	Prep Footing for Retaining Wall	1.000	Feb-06-24	Feb-08-24
F1050	FRP Retaining Wall	10.000	Feb-07-24	Feb-20-24
F1060	FRP Sewage Wall	3.000	Feb-21-24	Feb-23-24
F1070	Crews and Restore Site	2.000	Feb-26-24	Feb-27-24
G1000	Phase 1 FRP Pipeline	45.000	Nov-1-23	Feb-13-24
G1005	Locates	1.000	Nov-1-23	Nov-1-23
G1010	Process Bedding and Backfill	35.000	Nov-29-23	Jan-16-24
G1015	Stage FRP from Laydown Area	12.000	Nov-9-23	Feb-17-24
G1020	Strip Topsoil of Fields	5.000	Nov-20-23	Nov-29-23
G1030	Install FRP Manhole & Flange	35.000	Nov-29-23	Jan-15-24
G1040	Install Dewater ARV and Delivery Point	8.000	Jan-02-24	Jan-31-24
G1050	Prepare Trench and Clean-up	5.000	Feb-1-24	Feb-7-24
G1060	Testing of FRP	3.000	Feb-13-24	Feb-12-24
H1000	Phase 2 FRP Pipeline	60.000	Jan-04-24	Apr-01-24
H1070	Locates	1.000	Jan-04-24	Jan-04-24
H1080	Process Bedding and Backfill	50.000	Jan-31-24	Mar-19-24
H1090	Stage FRP from Laydown Area	10.000	Jan-31-24	Jan-22-24
H1100	Strip Topsoil of Fields	6.000	Jan-30-24	Jan-30-24
H1110	Install FRP Manhole & Flange - Crew 1	28.000	Jan-31-24	Mar-08-24
H1115	Install FRP Manhole & Flange - Crew 2	20.000	Feb-15-24	Mar-13-24
H1120	Install Dewater ARV and Delivery Point	8.000	Mar-14-24	Mar-29-24
H1130	Prepare Trench and Clean-up	5.000	Mar-26-24	Apr-02-24
H1140	Testing of FRP	5.000	Apr-01-24	Apr-01-24
H1400	Backfill Trench and Overhaul #1	25.000	Feb-26-24	Apr-1-24

Actual Level of Effort  
 Actual Work  
 Remaining Work  
 Critical Remaining Work  
 Milestone  
 Summary

## 2. Suggestions for Accelerating the Schedule

1. Native Backfill where suitable
2. Additional Crew & Equipment
3. Additional Access to Depot Land

## 3. Long Lead Items & Potential Impacts

LEAD TIMES FOR CRITICAL COMPONENTS			
Material	Supplier	ETA	Impact to Project
48" Steel from Northwest Pipe	Owner	10.30.23	None
Callies Material (Includes Casing)	Owner	9.29.23	None
FRP Pipe	Owner	11.1.23	None
Precast	Supplier	5 months after approved drawings	Finished drawings are critical to schedule. Preferably complete by July.
Steel Flanges	Callies Welding	3 weeks after approval	None
PEMB Building Shell	Supplier	12 weeks after approved drawings	Finished drawings are critical to schedule. Preferably complete by September.
HVAC	Subcontractor	10 weeks after approved submittals	None
Electrical Panels/Equipment	Subcontractor	6 months after approval	Approved submittals + ordering is critical to schedule. Submittals need approved by June.
Electrical Radio Towers	Subcontractor	4 months after approval	Approved submittals + ordering is critical to schedule. Submittals need approved by July.
Electrical Controls/PLC		5-6 months after approval	Approved submittals + ordering is critical to schedule. Submittals need approved by June.

**PROPOSAL SHEET**  
ITB-009 General Contractor

Line Item	Project Phase	Category	Task Description	Quantity	Unit of Measurement	Unit Price (USD)	Extended Price (USD)
1	Phase 1	Civil	Mobilization	1	LS	\$ 670,500.00	\$ 670,500.00
2	Phase 1	Civil	Electrical Building and Pump Station Foundation Excavation and Compaction	1	LS	\$ 15,000.00	\$ 15,000.00
3	Phase 1	Civil	Pump Station Site Grading	3000	YD	\$ 8.00	\$ 24,000.00
4	Phase 1	Civil	Pump Station Site Final Grading and 3/4" Gravel	250	YD	\$ 100.00	\$ 25,000.00
5	Phase 1	Civil	Pump Station Security Fence, Man Gate and Double 12ft Gates	550	LF	\$ 85.00	\$ 46,750.00
6	Phase 1	Structural	Pump Station Concrete Pad, Pedestals, 4" Drainage System	1	LS	\$ 87,350.00	\$ 87,350.00
7	Phase 1	Structural	Electrical Building Foundation and Mechanical Pads	60	YD	\$ 1,100.00	\$ 66,000.00
8	Phase 1	Structural	Pre-Engineered Steel Building (Furnish and Install)	1	LS	\$ 135,000.00	\$ 135,000.00
9	Phase 1	Electrical	Electrical Building Electrical, provide panelboards and all 120/208 circuits as required. Provide and install LED Lighting (interior and exterior (full perimeter) etc.)	1	LS	\$ 28,250.00	\$ 28,250.00
10	Phase 1	Mechanical	Electrical Building HVAC	1	LS	\$ 128,500.00	\$ 128,500.00
11	Phase 1	Electrical	Compressed Air Instrumentation and Electrical	1	LS	\$ 12,500.00	\$ 12,500.00
12	Phase 1	Mechanical	Airburst Compressor Installation, Piping and Appurtenances	1	LS	\$ 32,000.00	\$ 32,000.00
13	Phase 1	Mechanical	Air Burst System, Air Receiver Tank and Steel Pipe, Manifold, Valves and Stainless Steel Piping	1	LS	\$ 29,500.00	\$ 29,500.00
14	Phase 1	Civil	Airburst Pipelines, 6" SDR 9, PE4710, HDPE Pipe and Installation	1	LS	\$ 30,000.00	\$ 30,000.00
15	Phase 1	Structural	Hydropneumatic Tank Foundation (Strip Footings)	35	YD	\$ 1,000.00	\$ 35,000.00

16	Phase 1	Mechanical	Hydropneumatic Tank Installation and Furnish and Installing Piping to 48" Manifold	1	LS	\$ 173,000.00	\$ 173,000.00
17	Phase 1	Electrical	4160V Electrical Gear Installation (gear supplied by Owner) and 4160V Motor Wiring, Conductors and Conduit	1	LS	\$ 92,500.00	\$ 92,500.00
18	Phase 1	Electrical	Supply and install 480VAC MDP-B and all 480VAC Conduit and Wire.	1	LS	\$ 38,000.00	\$ 38,000.00
19	Phase 1	Electrical	Pump Station Instrumentation and Electrical (18" Flowmeters, Pressure Transducers, Level Transmitters, Motor Instrumentation etc.)	1	LS	\$ 73,000.00	\$ 73,000.00
20	Phase 1	Mechanical	Pump Discharge Manifold Installation	1	LS	\$ 120,000.00	\$ 120,000.00
21	Phase 1	Mechanical	Pump Station Discharge Piping	1	LS	\$ 38,000.00	\$ 38,000.00
22	Phase 1	Mechanical	Pump Station Pressure Relief Piping	1	LS	\$ 6,500.00	\$ 6,500.00
23	Phase 1	Mechanical	Pump Station Drain Piping and Existing Intake Manifold Modifications	1	LS	\$ 35,000.00	\$ 35,000.00
24	Phase 1	Civil	48" Flowmeter and Vault	1	LS	\$ 49,000.00	\$ 49,000.00
25	Phase 1	Civil	Steel Mainline Installation, 48", Stations -0+10 to 26+40	2650	LF	\$ 210.00	\$ 556,500.00
26	Phase 1	Civil	Steel Mainline Bedding/Backfill (Requiring Processing), 48", Stations -0+10 to 26+40	8000	YD	\$ 15.00	\$ 120,000.00
27	Phase 1	Civil	Mainline Thrust Blocking, Stations -0+10 to 26+40	40	YD	\$ 395.00	\$ 15,800.00
28	Phase 1	Civil	Shoreline Road Paved Open Cut Crossing	1	LS	\$ 6,750.00	\$ 6,750.00
29	Phase 1	Civil	HWY 730 Bore, 58", Stations 9+75 to 11+00	1	LS	\$ 345,000.00	\$ 345,000.00
30	Phase 1	Civil	Remove Existing Concrete Structure on North side of WEID Canal	10	yd	\$ 875.00	\$ 8,750.00
31	Phase 1	Civil	WEID Canal Crossing Structures	1	LS	\$ 149,350.00	\$ 149,350.00
32	Phase 1	Civil	WEID Earthwork	230	YD	\$ 60.00	\$ 13,800.00
33	Phase 1	Civil	Mainline Check Valve Assembly	1	LS	\$ 13,795.00	\$ 13,795

34	Phase 1	Civil	Mainline Check Valve Assembly Vault	1	LS	\$ 139,100.00	\$ 139,100.00
35	Phase 1	Electrical	65ft Radio Tower #1 and Foundation	1	LS	\$ 27,350.00	\$ 27,350.00
36	Phase 1	Electrical	Radio Tower #1, Electrical install (County to Provide Transformer within 75ft, Owner to provide Remote Station Cabinet (RSC))	1	LS	\$ 37,250.00	\$ 37,250.00
37	Phase 1	Civil	Security Fence and Man Gate	60	LF	\$ 125.00	\$ 125.00
38	Phase 1	Civil	Radio Tower# 1/ Check Valve Vault Site Final Grading and 3/4" Gravel	10	YD	\$ 150.00	\$ 150.00
39	Phase 1	Civil	FRP Mainline Installation, 1300mm, Stations 26+40 to 163+46	13706	LF	\$ 36.00	\$ 36.00
40	Phase 1	Civil	FRP Mainline Bedding/Backfill Material (Requiring Processing), 1300mm, Stations 26+40 to 163+46	31000	YD	\$ 8.80	\$ 272,800.00
41	Phase 1	Civil	FRP Mainline Top Soil Stripping, 1300mm, Stations 26+40 to 163+46	1	LS	\$ 25,000.00	\$ 25,000.00
42	Phase 1	Civil	Install 64" Steel Casing, 1300mm Carrier, End Seals, and Casing Spacers, Under Williams Gas Lines (Open Cut) (68+40 to 69+40)	100	LF	\$ 345.00	\$ 34,500.00
43	Phase 1	Civil	Mainline Airvent/Drain Assemblies and Vaults, 1300mm, Stations 26+40 to 163+46	7	EA	\$ 17,500.00	\$ 122,500.00
44	Phase 1	Civil	Mainline Thrust Blocks 1300mm, Stations 26+40 to 163+55	46	YD	\$ 395.00	\$ 18,170.00
45	Phase 1	Civil	COU Delivery Point, 48" Valves, Airvent and Vault Installation Station 163+55	1	LS	\$ 33,500.00	\$ 33,500.00
46	Phase 1	Electrical	COU Delivery Point, Electrical install (County to Provide Transformer within 75ft, Owner to provide Remote Station Cabinet (RSC))	1	LS	\$ 38,250.00	\$ 38,250.00
47	Phase 1	Electrical	COU Delivery Point Instrumentation and Electrical (20" Flowmeter and Pressure Transducers)	1	LS	\$ 6,500.00	\$ 6,500.00
48	Phase 1	Civil	COU Delivery Point, Flowmeter and Vault	1	LS	\$ 47,925.00	\$ 47,925.00
49	Phase 1	Civil	COU Delivery Point, Airvent Assembly and Vault	1	LS	\$ 18,600.00	\$ 18,600.00
50	Phase 1	Electrical	65ft Radio Tower #2 and Foundation	1	LS	\$ 27,350.00	\$ 27,350.00

51	Phase 1	Civil	COU Delivery Point Site Final Grading and 3/4" Gravel	100	YD	\$ 86.00	\$ 8,600.00
52	Phase 1	Civil	COU Delivery Point Security Fence, Man Gate and Double 12ft Gates	350	LF	\$ 87.00	\$ 30,450.00
53	Phase 1	Civil	Phase 1 Pressure Testing	1	LS	\$ 35,000.00	\$ 35,000.00
54	Phase 1	Civil	Punch Lists, Cleanup and Alignment/Road/Laydown Yard Rehabilitation	1	LS	\$ 71,000.00	\$ 71,000.00
55	Phase 1	Civil	Phase 1 Rock Excavation Rate	1	yd	\$ 200.00	\$ 200.00
56	Phase 1	Civil	Phase 1 Contingency Allowance	1	LS	\$250,000.00	\$250,000.00
<b>Phase 1 Subtotal</b>							
57	Phase 2	Civil	FRP Mainline Installation, 1300mm, Stations 163+64 to 196+16	3252	LF	\$ 39.65	\$ 128,941.80
58	Phase 2	Civil	FRP Mainline Bedding/Backfill (Requiring Processing), 1300mm, Stations 163+64 to 196+16	8000	YD	\$ 10.00	\$ 80,000.00
59	Phase 2	Civil	Mainline Airvent Assemblies and Vaults, 1300mm, Stations 163+64 to 196+16	1	EA	\$ 14,000.00	\$ 14,000.00
60	Phase 2	Civil	FRP Mainline Installation, 1100mm, Stations 196+28 to 336+00	13972	LF	\$ 43.60	\$ 609,179.20
61	Phase 2	Civil	FRP Mainline Bedding/Backfill (Requiring Processing), 1100mm, Stations 196+28 to 336+00	31000	YD	\$ 12.50	\$ 387,500.00
62	Phase 2	Civil	Mainline Airvent/Drain Assemblies and Vaults, 1100mm, Stations 196+28 to 336+00	6	EA	\$ 17,500.00	\$ 105,000.00
63	Phase 2	Civil	Mainline Thrust Blocks, 1100mm, Stations 163+55 to 336+00	50	YD	\$ 425.00	\$ 21,250.00
64	Phase 2	Civil	1300mm x 1100mm Tee Station 196+22	1	LS	\$ 11,750.00	\$ 11,750.00
65	Phase 2	Civil	Ordnance Lateral Tee's, Airvents, 42" Valves and Vaults Station 270+61	1	LS	\$ 34,350.00	\$ 34,350.00
66	Phase 2	Civil	Depot Paved Road Open Cut Crossings	1	LS	\$ 6,000.00	\$ 6,000.00
67	Phase 2	Civil	Recharge Basin Delivery Point Manifold, Flowmeter, Airvent, Vaults and 42" Valve Installation Station 336+00	1	LS	\$ 96,425.00	\$ 96,425.00



68	Phase 2	Electrical	65ft Radio Tower #3 and Foundation	1	LS	\$ 27,350.00	\$ 27,350.00
69	Phase 2	Electrical	Recharge Basin Delivery Point, Electrical install (County to Provide Transformer within 75ft, Owner to provide Remote Station Cabinet (RSC))	1	LS	\$ 39,935.00	\$ 39,935.00
70	Phase 2	Electrical	Recharge Basin Delivery Point Instrumentation and Electrical (42" Flowmeter and Pressure Transducers)	1	LS	\$ 4,615.00	\$ 4,615.00
71	Phase 2	Civil	Radio Tower# 3/ Recharge Basin Delivery Point Site Final Grading and 3/4" Gravel	25	YD	\$ 110.00	\$ 2,750.00
72	Phase 2	Civil	Punch Lists, Cleanup and Alignment/Road/Laydown Yard Rehabilitation	1	LS	\$ 57,500.00	\$ 57,500.00
73	Phase 2	Civil	Phase 2 Rock Excavation Rate	1	YD	\$ 200.00	\$ 200.00
74	Phase 2	Civil	Contingency Allowance	1	LS	\$ 125,000.00	\$ 125,000.00
						Phase 2 subtotal	\$ 175,740.00
						Total Amount	\$ 6,718,202.00

KT (Please Check or Initial) Proposer will comply with the provisions of ORS 279C.800 -.870, including the payment of the applicable prevailing rate of wage.

Proposer certifies this proposal is valid for 60 calendar days.

Proposer Tapani Inc.

Address 1705 SE 9th Ave, Battle Ground, WA 98604

By (Print) Kevin Tapani

By (Signed) *Kevin Tapani*

## 5.9 FINANCIAL INFORMATION

### 1. Bonding Capacity



**Tanner Varin, AFSB, MST**  
Account Executive  
Travelers Bond & Specialty  
Insurance  
4000 Kruse Way Pl, Suite 100  
Lake Oswego, OR 97035  
Phone: 503-534-4294  
tvarin@travelers.com

March 24, 2023

IRZ Consulting, LLC  
500 North First Street  
Hermiston, OR 97838

RE: Tapani, Inc. Prequalification Letter – Ordnance Multi-Use Water Project

To Whom It May Concern:

Travelers is pleased to provide this letter of reference for our client, Tapani, Inc. (Tapani) regarding their surety capacity. Tapani has continuously been a client of Travelers Casualty and Surety Company of America since 1999 and have proven their skills and abilities by completing numerous technical and challenging projects. Tapani has demonstrated an excellent performance record based on sound planning, close project controls, knowledge of government requirements, and tireless efforts. We hold Tapani in the highest regard.

Travelers Casualty and Surety Company of America has prequalified Tapani for performance and payment bonds with a single bonding capacity of \$125,000,000 and an aggregate bonding capacity of \$500,000,000.

Please understand that this letter is given with the understanding that issuance of any bond(s) requires the satisfactory review of the contract documents, project financing, and bond forms. Any arrangement for bid and/or final bond(s) is a matter between our client, Tapani, and Travelers Casualty and Surety Company of America and we assume no liability to third parties or to you if, for any reason, we do not execute said bond or bonds.

Travelers Casualty and Surety Company of America is an A++ rated firm by A.M. Best and is listed on the Treasury Department Circular 570.

If you have any questions, please do not hesitate to contact me.

Sincerely,

A handwritten signature in black ink, appearing to read "Tanner Varin". The signature is fluid and cursive.

Tanner Varin  
Travelers Bond & Specialty Insurance

# 5.10 ADDITIONAL INFORMATION

## 1. Tapani's In-House Designed/Fabricated Stinger Operation

While working on the East Irrigation District project, Tapani's construction team worked with our in-house fabrication shop to design and build a specialty equipment attachment that lifts pipe up from the inside without damaging it- called the "sting". With heavy load capabilities, this greatly increased productions around the unloading and staging of pipe sticks.

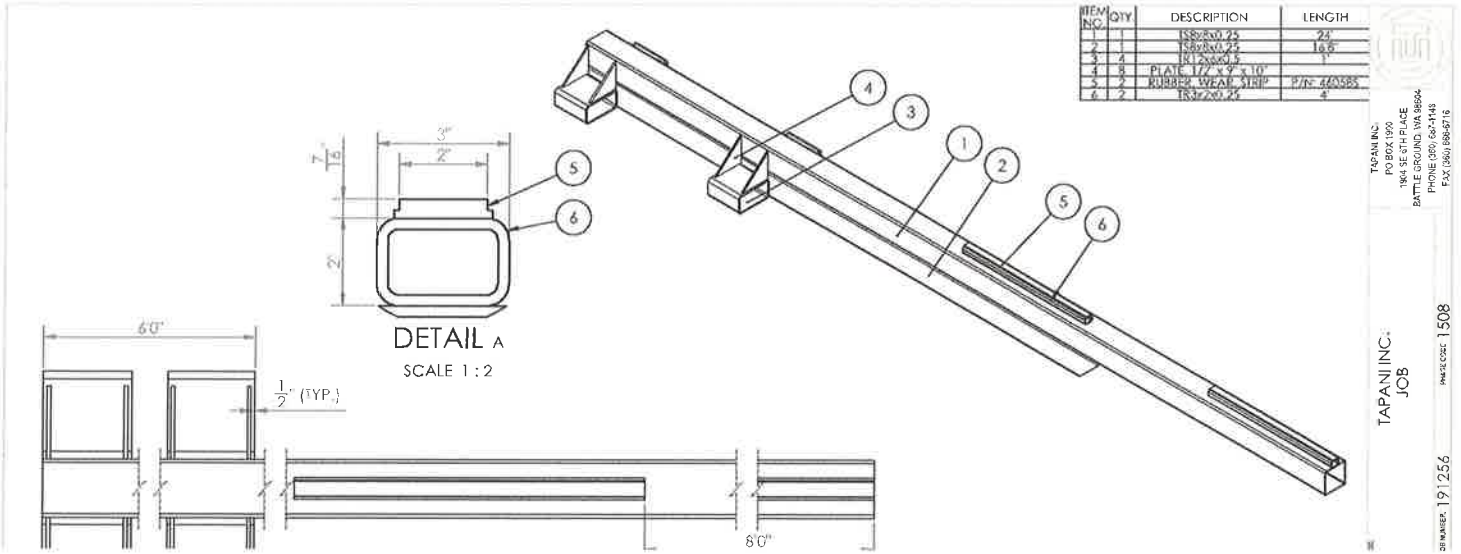

## 2. Tapani's Safety Management Program

Tapani's continuously integrates safety as a core value in our company structure as a whole, as well as individually in each of our employees. Our Safety and Health Management System aims to thoroughly understand and eliminate job site hazards, prevent all possible incidents through proactive prevention plans, and ensure continuous education and safety awareness in our employees. Our goal is to daily protect our employees, subcontractors/suppliers, the public, and the environment while ensuring a project's performance and profitability. Tapani's Safety and Health Management System is made up of the following five components.

### CURRENT EMR RATE

#### TAPANI'S EMR RATES FOR LAST 5 YEARS

Industry Average = 1

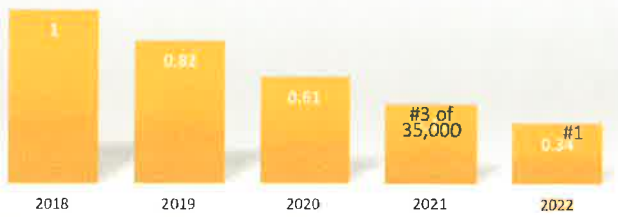

Tapani's current EMR rate scores well below the industry average of 1 at .34, making us the #1 company in Safety Ratings out of 35,000 in Washington. Notably, as Tapani has increased our focus on implementing safety as a core value and practice in everything we do, the last 5 years have continuously seen a downward trend in our EMR ratings, as shown in figure 2. The implementation of increased safety management personnel and safety evaluation systems, safety as a core practice of our employees and partners, and cultivating a culture where safe practices and forethought is celebrated and rewarded has allowed our teams to bring a high level of safety to every job site. Protecting the health of our communities, employees, and partners at all times while maintaining a productive job site is our highest priority.

### SAFETY MANAGEMENT, INSURANCE, & RESOURCES

**MANAGEMENT** Tapani's Safety Department is made up of a Health & Safety Director (1), Safety Coordinator (1), Safety Officers (3), and project-specific safety supervisors (numbers change dependent on job requirements). These individuals are dedicated full-time to maintaining Tapani's safety culture, tracking, education, and improvement.

**INSURANCE** Starting October 1st, 2021 Tapani became captive with AGCR rather than having a typical insurance company. This implies that Tapani's safety standards are in line with the top leading companies in the Pacific Northwest and requires continual pursuit and results of maintaining these standards.

**SAFETY RESOURCES** Tapani is dedicated to going above and beyond for our employees. We understand that if safety resources are made easily available, the more likely it is that employees can confidently maintain their own safety, the safety of others, and job site safety.

**PPE Gear:** Tapani has a Small Tools Department that provides a variety of tools and safety gear that is available at all times for employees at no cost. We provide all necessary safety gear that our crews might need as well as ladders, rescue retrievals, and harnesses. Rather than placing the burden of maintaining safety equipment/PPE gear on our individual employees, our Safety Coordinator performs safety gear audits every 6 months. Additionally, Tapani's Safety Coordinator regularly finds ways to better our safety gear, such as attaching feet straps to harnesses that extends the 6 hours a person can be suspended prior to death from clamped blood supply in the legs by providing a means of standing.

**Mental/Physical Health Safety:** As personal, professional, and political atmospheres become more stressful, we have seen a rise in critical mental health issues and physical health issues. Nationally, construction workers are five times more likely to die by suicide than be injured from job-site accidents. To provide support to our employees, Tapani has implemented an Emergency Assistance Program that provides immediate assistance to any of our workers struggling with mental health. Additionally, Tapani has a Health and Wellness program that encourages physical health by providing resources and company-wide health challenges.

**JOB SITE SAFETY RESOURCES** Tapani's app now has a specific safety tab where employees can access and reference safety data on-site. It contains tabulated safety data sheets, how-to's, accident prevention, etc. In the near future, the app will also hold an incident report capability as well.

## JOB SITE SAFETY IMPLEMENTATION

**PROJECT START** Prior to a Notice to Proceed, Tapani's safety officers meet on site with the project Superintendent to create a Job Hazard Analysis report. These reports generate a site-specific Job Hazard Approach Plan that is given to employees and posted in the job-site trailer.

**DAILY PROJECT SAFETY DAILY PRE-TASK PLAN** Tapani begins every morning with a team review of the daily pre-task plan, which focuses on evaluating specific task hazards for the day, steps for hazard mitigation, and individual personnel safety checks. Any time there is an additional task added, crews re-evaluate and update the daily pre-task plan.

**STRETCH & FLEX** To mitigate sprains and strains, crew members are required to stretch every morning prior to working.

**TASK HAZARD ANALYSIS AND PLAN** Site Superintendents, Tapani Safety Officers, and key subcontractors collaborate to create specific Task Hazard Analysis Plans that are used to control task-specific safety risks.

**MONDAY MORNING COMMUNICATIONS** Tapani holds a 1-hour Monday Morning Communications meeting company wide. Weekly safety trends, accomplishments, and necessary-forward actions are reviewed.

## JOB SITE SAFETY IMPLEMENTATION

### TAPANI'S SAFETY OFFICERS (3)

- Visit jobsites daily and perform OSHA audits on every project. On average, Tapani's Safety Officers perform 600 job site inspections yearly.
- Consult with OSHA yearly.
- Create Incident reports and Near Misses that are used to create RCA's (Root Cause Analysis) Reports.

### SAFETY COMMITTEE MEETING

- Meets once per month, with representatives from all company departments
- Analyzes RCA trends and leading indicator trends, which are then reported company-wide through an email report. Analyses help our teams manage performance in our commitment to safety, find ways to effectively prevent repeats, and provide key safety focus areas for our teams to work on.
- Determines necessary accident investigations.
- Focus on creating company-wide leading indicators to improve performance in any negative safety trends.

### EMPLOYEE/TEAM SAFETY REWARDS

Tapani deeply values rewarding individuals, crews and projects for producing outstanding safety records on their projects. We regularly reward employees and teams by giving out giftcards, sending our Tapani barbeque truck on-site to provide lunch for project crews, and having our safety officers bring coffee or pizza out to crews.

## IMPROVEMENT FOCUS

**Tapani is committed to a continuous effort to grow and better our safety program and culture at all times!** The following are continuous actions we take to work towards that goal:

- Sharing near-miss reports across the company.
- Working with Oregon OSHA SHARP Alliance to become VPP.
- Modifying our Safety Program and Department as needed to ensure the highest value safety team.
- Consistently updating our Accident Prevention Program, an easily accessible resource to our field teams.

## JOB HAZARD ANALYSIS

Tapani's Job Hazard Analysis process aims to achieve zero recordable job-site injuries. Prior to the construction, Tapani personnel (Tapani Safety Officer, Project Manager, and Site Superintendent) meet on-site to evaluate the project scope and understand how the scopes of work will be influenced by the site itself. The ensuing Job Hazard Analysis reports captures the work that will be performed, the potential accompanying safety hazards of that work in accordance to location onsite, and the safety precautions and systems that will be out in place on the project to minimize the identified risks.

## SUBCONTRACTOR SAFETY MANAGEMENT

Tapani values maintaining the safety of our Owner's Representatives, on-site crews, and the impacted public is of the highest importance on our project sites. Tapani utilizes a pre-hire checklist for subcontractors. We look at their EMR ratings and will not hire a subcontractor that has a lower than average rating.

Tapani goes through a detailed and thorough selection process as we firmly believe we are only as successful as our partners. As subcontractors work on Tapani sites, they are subjected to the same safety requirements and standards as Tapani crews. Tapani will hold orientation meetings for all new subcontractors that arrive on-site, to orientate them with Tapani safety requirements and standards and the project's PPE requirements. Subcontractors are required to understand the project's goals, other subcontractor work paths and allowed work areas prior to starting their scope of work. If any potentially hazardous items of work are identified in the Pre-Task Hazard Analysis, the Project Manager and subcontractor will create a plan for performing the work that outlines solutions to controlling and mitigating the task risks.

## TRAINING

**ANNUAL TRAINING** In 2019, Tapani built our specialized training facility at our TEBO rock site. Annually, we hold safety training/certifications for certifications such as confined space competent person, rigging and signaling, First Aid/CPR, etc.

**MONTHLY TRAINING** Every month, Tapani holds a level one training. These level one trainings are required for anyone new to the field and educate all employees on basic safety standards and practices in the field. We have an on-boarding safety video. Implementing a forman/superintendent safety training.

**POSITION-SPECIFIC TRAINING** Tapani is now implementing a Forman/Superintendent safety training for every employee that is planning on transitioning into these positions. These position-specific trainings focus on leadership in safety, maintaining over-all safety of a job-site and crews, and ensure that all necessary certifications are in place.

**ONBOARDING SAFETY TRAINING** Tapani is in the process of implementing an on-boarding safety video and discussion piece into our on-boarding class for every new employee, despite the department they will be working in. We see this as a critical step towards maintaining a safety culture and instilling safety as a core value in every aspect of our business.

## 5.11 KEY SUBCONTRACTORS

### 1. Callie's Welding and Fabrication LLC



Callies is a family owned company that strives for excellence in all aspects of pipe and miscellaneous metal fabrication. The company was established in 2010 by Kyle Callies along with his wife, Allynda, who were determined to create a friendly, productive, and, most importantly, safe work environment. Determination, hard work and good public relationships were all necessary components in starting and operating their successful business. We still operate the same way today. Without solid employees, valued customers, and sheer determination, Callies would not be the whole and well-rounded business it is today. Callies is always taking on and searching for the “hard and impossible projects” with tight deadlines and customers who will except nothing but the best: not searching for awards or public notoriety. At the end of the project, Callies is pleased from a project being a smooth operating system, whether it be a natural gas pipeline, water treatment plant or pipeline, or a simple bracket for someone in need of a favor. No matter how big our company grows, the customer and end user must feel that they were treated right, their project was the priority, and the product provided was nothing but the best.

**DEDICATED TEAM MEMBER: Kyle Callie.** Kyle brings a history of working with Tapani on key irrigation / pipeline projects such as DNR Paterson Pipeline, East Irrigation District Pipeline, Amstad Farm Update, Snake River Orchard, and Internet Parkway Utility Improvements for the Port of Morrow.

### 2. Prairie Electric



Prairie has years of experience in Commercial, and Industrial. PE have years of experience with the following Design/Build, BIM, Directional Boring, Utility Work, Switchgear, Medium Voltage, Fire Alarm, to name a few. Job experience, Reeser,s Fine Foods Hillsboro and Pasco, Beaverton Middle School, Costco, Chehalem Aquatic Center, Multiple Pump Stations. Prairie Electric Inc employee's that will be performing the work include:

**DEDICATED TEAM MEMBER: Dwayne McDaniels.** Journeyman Electrician, has worked on multiple pump stations, waste water treatment plants, storm water pump station, also a medium voltage 2,400V pump station for Columbia Irrigation District including new MDP, new XFMR, conduit, wire, and terminations. He also has replace a 60,000lb XFMR for Quincy-Columbia Irrigation District, 115kv to 2,400V XFMR, new busing to MDP, replaced insulators and switching on the 115kv side. He also worked in Washington Corrections Center in Shelton, WA replacing 12,470V to 480V transformers, MDP's, and installing generators.

**DEDICATED TEAM MEMBER: Dean Raisanen.** 3 years in Industrial, some at Cadman Materials at their Coyote Springs Sand and Gravel pit on conveyors, Industrial Food facilities, Medium Voltage in a Mining enviroment.

### 3. Columbia Allied Services | HVAC Design & Build



Starting in 2001 as Columbia Gas & Fireplace, Columbia Allied Services quickly grew into a dynamic and experienced team of professionals that now provide commercial and industrial HVAC design and implementation, commercial and industrial plumbing, and piping systems.

**DEDICATED TEAM MEMBERS: Randy Massie (Project Manager)** has worked with Tapani's team on Salmon Creek WWTP HVAC upgrades and performed similar scopes on Stevenson Waste Water Treatment Plant. Additionally, he brings design/build experience with the following projects:

- Superior Tire
- River Mill RV Park
- Peak Performance Gym
- Pacific Star Excavating
- Bridge City Golf
- Holyk Office Remodel

#### 4. Frontier Fence, Inc



Frontier Fence, Inc. is a family owned and operated fence company that has been serving the Tri-Cities and surrounding area since 1970. Specializing in residential, commercial, industrial, municipal and government sectors, Frontier has successfully serviced thousands of customers over the years.

**Key Team Members:** Brad Snuggs, Joe Clifton, Garret Whitney, Kameron Snuggs, Stewart Johnson.

**Past Experience:** Altogether, this team represents 53 years of experience in numerous industrial facilities projects. Key projects include the East Irrigation District projects (With Tapani) and Handford Industrial Site.

#### 5. Gonzales Boring & Tunneling Co.



Gonzales Boring and Tunneling Co., Inc. is a specialty underground contractor, specializing in the trenchless installation of utilities for over 39 years in the Northwest. James Gonzales is the owner and president of Gonzales Boring and Tunneling Co., Inc. The Gonzales family has been installing trenchless utilities in the Portland area since 1962.

Gonzales Boring and Tunneling has expertise in various sizes of casing/utility installation ranging from 8" diameter to 144" diameter with distances of over 1,000 feet in lengths. Many of the crossings installed involve water or sewer pipe installation through a bored casing. GBT, Inc. crews are expert at not only the trenchless installation of the casing, but the installation of the carrier pipe as well.

Gonzales Boring and Tunneling is a Certified Minority Contractor in the State of Oregon and has 20 full-time employees, which 50% are minority. The average GBT employee has over 15 years of trenchless experience. GBT is a signatory member contractor with the International Operating Engineers as well as the Laborers. With a close involvement and investment with the Operating Engineers Boring Machine Training Program, GBT is helping to ensure that qualified personnel will be available for the future. GBT personnel are continually trained in safety procedures and hazards in the workplace. Gonzales Boring and Tunneling, Inc is a member of the National Utility Contractors Association,

**Tapani has an outstanding history working with Gonzales on the following projects:** Roy Rogers Road Improvements, North Junction Pump Station and Trunk, Lacamas Creek Sanitary Sewer Pump Station, Buter Creek Water Development, Ice Harbor Phase 2C, Hillside Phase 2, and Grant Butte Reservoir Improvements.